

Previous Show's Guide

SOUTHEASTERN FLOWER SHOW 2006 EXHIBITOR'S GUIDE

Inspiration, Education, Entertainment...
The Italian Experience

February 8-12

GEORGIA WORLD CONGRESS CENTER
Hall C off Northside Drive adjacent to the Georgia Dome
Atlanta, Georgia

GENERAL INFORMATION

TICKETS

(sales tax included)

Advance Ticket (sold through February 7, 2006)	\$15
General Admission Ticket	\$18
Student Ticket (9th Grade through graduate school - ID required)	\$ 8
Youth Ticket (1st through 8th Grades) (Children 5 and under admitted free)	\$ 6
All-Access Ticket (Allows entry any and all days of Show - no coupons apply)	\$35
Twilight Ticket (Admission after 4:00 p.m. Wednesday-Friday - no coupons apply)	\$10

Group Ticket Prices Upon Request (15 or more) call 404-351-1074

Advance tickets may be purchased at www.flowershow.org,
by calling 404-351-1074, or at select retail locations.

HOURS

Wednesday, February 8	10:00 a.m. - 8:00 p.m.
Thursday, February 9	10:00 a.m. - 8:00 p.m.
Friday, February 10	10:00 a.m. - 8:00 p.m.
Saturday, February 11	10:00 a.m. - 8:00 p.m.
Sunday, February 12	10:00 a.m. - 6:00 p.m.

Presenting Sponsor:

PIKE FAMILY NURSERIES

Southeastern Flower Show

1705 Commerce Drive, N.W., Suite 400, Atlanta, GA 30318
Phone: 404-351-1074 Fax: 404-351-1075
www.flowershow.org

SOUTHEASTERN FLOWER SHOW MISSION STATEMENT

The Southeastern Flower Show is an independent, nonprofit, volunteer-based organization that is dedicated to promoting horticultural excellence and the conservation of our natural environment. One of its major activities is to organize an annual flower and gardening show with the continuing goal of being the premier juried gardening and horticultural event in the Southeast and a major cultural event for Metropolitan Atlanta. Participation in this event is open to all. Additional activities of the organization provide opportunities for the teaching of gardening, landscaping, and floral design skills.

To strengthen and extend its outreach, the Southeastern Flower Show supports and partners with other nonprofit groups that are committed through their environmental endeavors to making communities better places to live and work.

SOUTHEASTERN FLOWER SHOW LEGACY GARDEN

The SFS Legacy Garden, a gift from the Southeastern Flower Show to the Atlanta community, was begun in 1994 as a way to use plant material that was left at the end of the Flower Show. The project has evolved into a collaborative effort among the Show, its exhibitors, and Atlanta area businesses and civic clubs to leave a lasting legacy to the community.

The 2006 Legacy Garden will benefit the Wesley Woods Horticultural Therapy Program.

The Southeastern Flower Show Legacy Garden has been used to beautify the following locations:

- 1994 Amberwood Village, Reynoldstown
- 1995 City Hall East
- 1996 Fourth Ward Neighborhood
- 1997 House of Love and Hope, foster home for young children
- 1998 The Bridge, residential treatment center for abused children
- 1999 The Lang-Carson Community Center, Reynoldstown
- 2000 The Samuel L. Jones Boys and Girls Club, Decatur
- 2001 Charles R. Drew Charter School, East Lake Neighborhood
- 2002 Cook Elementary School and C.W. Hill Elementary School, Atlanta Public Schools
- 2003 Historic Oakland Foundation, Oakland Cemetery
- 2004 Historic Oakland Foundation, Oakland Cemetery
- 2005 Emory Healthcare's Winship Cancer Institute at Emory University (Healing Garden Project)

TABLE OF CONTENTS

SFS Information

General	.1
Mission Statement	.2
Legacy Garden	.2
Show Events	.3
Staff	.3
Board of Trustees	.4
Show History: Chairmen and Show Themes	.4
2006 Juried Competition Leadership Committee	.5
Invitation from the 2006 Show Chair	.6

Competitive Classes

General Rules	.7
Artistic Floral Design Division	.11
Discovery Division	.16
Garden Design Division	.17
Horticulture Division	.21
Landscape Division	.32
Photography Division	.33
Professional Design Division	.35
Youth Division	.37
Awards	.38

Forms

Entry Forms	.45-53
Statement of Purpose Form	.55
Plant List Form	.57

Georgia's Endangered and Protected Plants59

Map & DirectionsCenterfold for easy detachment

Please note: The information in this Exhibitor's Guide was accurate at presstime, but changes may have occurred since its publication. Please check www.flowershow.org for updates.

2006 SHOW EVENTS

Opening Night Party	Tuesday, February 7
Garden Club Day	Wednesday, February 8
Home School and Field Trip Day	Thursday, February 9
Girls' Night Out	Thursday, February 9
Flower Power Party	Saturday, February 11
Awards Ceremony	Saturday, February 11
Youth Division Awards Ceremony	Sunday, February 12
Family Frolic	Sunday, February 12

SOUTHEASTERN FLOWER SHOW STAFF

Executive Director	.404-351-6051
Senior Director of Show Production	Sue Freese404-605-8458
Director of Marketing	Ginny Nickles404-351-0346
Director of Administration	Stephanie Cicerone404-351-6208
General Information	.404-351-1074
Fax	.404-351-1075

Ryan GaineyArtistic Director404-377-1494
--

BOARD OF TRUSTEES

Diane Festa, President

Louise Adams	Flossie Dodge*	Cary Lide	Eileen Small
Anna Bradley*	Katharine Elsas*	Dan Martin**	Alex Smith
Terry Broscher	Sharon Flores*	Peggy Martin**	Dean Smith
Sara Jean Burke*	Dottie Fuqua**	Anna Mershon	Andrea Strickland*
Denise Caffrey	Ryan Gainey**	Joanie Michaels*	Danny Summers
Minnie Bob Campbell	Charles Ganz	Felton Norwood	Dollie Swanson
Jim Carson	Caroline Gilham*	Malinda King O'Neal	Ray Thompson*
Ed Castro	Dan Haas	Eldon Park	Pat Tuff*
Gracia Conn	Pat Hartrampf*	Cathy Perry	Sandy Turbidy*
Charlotte Day*	Ann Hill*	Bill Pinkston**	Marsha Webb
John Drake	Sally Hinkle*	Bill Plummer	Ellen Wiley
Teresa Edmisten	Beverly Howell	Walter Reeves	Kimberlee Wilson
Kappy deButts	Bill Killmer**	Jane Ridall	Cappa Woodward*
Mary Wayne Dixon	Larry Klamon		

* Honorary Members of Board of Trustees

** Honorary Ambassadors to Board of Trustees

SHOW HISTORY

Chairman	Theme
Pat Hartrampf1988 Prelude to Spring
Pat Hartrampf1989 A Southern View
Mary Morrison1990 Windows on the World
Sandy Turbidy1991 Fantasia: An Adventure in Myth, Fable & Fantasy
Caroline Gilham1992 Presidential Pathways
Ray Thompson1993 At the Movies
Ann Hill1994 The Artist's Eye
Sally Hinkle1995 Celebrations!
Flossie Dodge1996 Welcome the World with Flowers
Katharine Elsas1997 Rhythm in Bloom
Joanie Michaels1998 Come To Your Senses, A Garden Awakening
Pat Tuff1999 Salute to the Century, A Farewell with Flowers
Sara Jean Burke2000 Through the Garden Gate
Sharon Flores2001 Gardens of Poetry & Prose
Cappa Woodward2002 Garden Treasures
Charlotte Day2003 Laughter in the Garden
Anna Bradley2004 Moments in a Southern Garden
Andrea Strickland2005 English Gardens for Southern Lifestyles

2006 JURIED COMPETITION LEADERSHIP COMMITTEE

2006 Show ChairMinnie Bob Campbell	.770-955-8763minniebcampbell@aol.com
Show Chair ElectDenise Caffrey404-352-1669consulaw@aol.com
Artistic Floral Design			
Division Co-ChairsJanet Patterson404-892-2238janet483@earthlink.net
	Ellen Wiley404-355-9831ellenwileydesign@aol.com
Awards Co-ChairsKay Alvelda404-352-1676k@alvelda.com
	Ann Beccia404-355-4342typeab@earthlink.net
Clerks ChairLynne Thomas770-992-4623lynney@mindspring.com
Discovery Division			
Co-ChairsSara Henderson404-233-2712gardenmakers@att.net
	Jim Hinkle404-255-7140jehinklemd@mindspring.com
Exhibitor's GuideAngi Evert404-256-2220awevert@aol.com
	Caroline Gilham404-355-0245c.gilham@mindspring.com
Garden Design Division			
Co-ChairsStephanie Nelson770-594-6820hnelson01@bellsouth.net
	Gloria Ward770-956-7734	
Horticulture Division			
Co-ChairsDenise Caffrey404-352-1669consulaw@aol.com
	Emily Johnson404-816-8087c6120@aol.com
Judges ChairTerry Waith404-252-4473terrywaith@mindspring.com
Judges Chair AdvisorsVirginia Almand404-355-0736valmand@bellsouth.net
	Carolyn Hawkins770-471-2841crh9999@aol.com
Artistic Judges ChairTrudy Huger404-233-1332	
Horticulture Judges ChairAudrey McMenamy404-351-8687	ahmcmenamy@mindspring.com
Landscape & Discovery			
Judges ChairMary Palmer Dargan	404-354-1715mpdargan@dargan.com
Judges Hospitality			
Co-ChairsGinny Plummer404-237-4759ginny.plummer@comcast.net
	Priscilla Hopkins404-352-1759phop95@yahoo.com
Juried Competition ChairMicki Gambrell404-872-5762agambrell@aol.com
Landscape Division			
Co-ChairsAndrea Huff770-521-1772pgazhuff@earthlink.net
	Ellen Ungashick404-255-8932ungy@earthlink.net
Photography Division			
Co-ChairsJennifer Clements770-333-8753	
	Maria Mixson404-355-7778	
Professional Design Division			
Co-ChairsElizabeth Martin404-351-8208elizmartin@aol.com
	Stella Martin404-351-0938stellaiii@comcast.net
Youth Division ChairDian Deimler404-874-3744ddeimler@bellsouth.net

AN INVITATION FROM THE 2006 SHOW CHAIR

Dear Exhibitor,

Welcome to the Southeastern Flower Show - the premier horticultural and gardening event in the region. The theme of the 19th annual Show is:

*"Inspiration, Education, Entertainment...
The Italian Experience."*

I invite you to join us as we explore the many facets of Italian culture - from opera, film and fashion to food and wine - and the influence they have had on garden making in the Southeast.

You will find in the pages of this Exhibitor's Guide wonderful ideas for competitive Classes - ranging from an 1,800 square foot landscaped garden all the way down to a small container holding one exquisite camellia blossom. In the Artistic Floral Design Division, stretch the limits of your creative abilities by interpreting a Roman god using a monochromatic palette of plant material. In the Garden Design Division, help create the piazza of an Italian village by embellishing the balcony of a famous Italian with Italian-inspired container plants. For you professionals out there, the sky's the limit (or the ceiling of the Georgia World Congress Center anyway) in your interpretation of "La Dolce Vita." I invite everyone - professional and amateur, young and old - to participate in this year's Show and to immerse yourself in "the Italian Experience."

We have over fifty competitive Classes to inspire you! All the information you need for how, when and where to enter is in this Guide. You will find listings of divisional chairs, entry chairs and class advisors also. These Juried Competition experts are ready and willing to help answer your questions and guide you through the entry, installation and judging process.

So, let's get started!

Ciao,

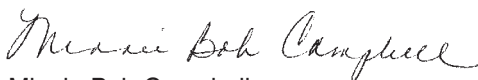

Minnie Bob Campbell

P.S. I invite you to join our team of dedicated volunteers. Call the Show office at 404-351-1074 or email us at volunteer@flowershow.org.

GENERAL RULES

Exhibitor agrees to abide by and be governed by conditions set forth below.

- 1. HOW TO ENTER:** Entries may be made by using the Entry Forms provided at the end of this Guide (see pages 45-53). Entries in the Horticulture Division may also be made online at www.flowershow.org. Additional Entry Forms may be photocopied, downloaded from the SFS website, or requested by calling 404-351-1074.

Entries may be mailed to the Division Entry Chair. Faxed entries are allowed only in the Professional Design Division.* Do not mail or fax entries to the SFS Office. See appropriate Division section of this Guide for Division Entry Chair contact information. Entries will be accepted and acknowledged in the order received until the Division deadline date or until Classes are filled. Please see the appropriate Division Rules for additional entry requirements.

- 2. GROUP/INDIVIDUAL ENTRIES:**

- a. A Group Entry is a single entry made by more than two members of a garden club, plant society, scout troop or other organization. While an entire garden club or other group may plan and work on a group exhibit prior to the Show, a maximum of eight* members of the group may work on the Show Floor at a given time installing the exhibit; and only two names may be listed on the Entry Form as contact persons. Only the group name will be listed on the Show Card. Two Exhibitor passes will be given to the group.

Group Entries and Co-Exhibitors are not permitted in the Horticulture Division.

Group Entries are permitted in the Artistic Floral Design, Youth, and Garden Design Divisions in designated Classes only; see pertinent Division Rules and/or Class listings for identification of these Classes.

- b. An Individual Entry can be one Exhibitor or an Exhibitor and Co-Exhibitor, but not more than two people.
- 3. NOVICE CLASSIFICATION:** The intent of the Novice Classification is to encourage participation in the Flower Show of new, unseasoned Exhibitors. The definitions of Novice for specific Divisions are as follows:
 - a. An Individual Exhibitor in either the **Artistic Floral Design** or **Garden Design Divisions** who has not previously won a Blue or Red ribbon (First or Second place) in any Class of a Design Division at a major flower show. The Novice Classification remains during both judging periods.
 - Individual Entries: Both Exhibitor and Co-Exhibitor (if applicable) must be novices and must be the sole designers of the exhibit.
 - Group Entries do not qualify for the Novice Classification.
 - b. An Exhibitor in the specified Novice classes of the Horticulture Division who has not won a Blue or Red ribbon (First or Second Place) in any of the Horticulture Classes at a major flower show.

- 4. PLANT IDENTIFICATION:** Correct botanical names are required for each exhibit. Please use the following guide to assist you with proper entry.

Genus: first letter is upper case, all other letters are lower case;

Species, subspecies, form and variety: all letters are lower case;

Hybrid: first letter of each word is upper case, all other letters are lower case;

Cultivar: first letter is upper case, all other letters are lower case, with single quotes;

Common Name: first letter of each word is upper case, all other letters are lower case.

*Indicates important change.

GENERAL RULES (Continued)

Species Example:

Hedera helix ‘Needlepoint’ English Ivy

Named Hybrid Example:

Laeliocattleya Color Guard ‘Hawaii’ Orchid

Unnamed Hybrids: List both plant parents separated by an X. Follow the capitalization guidelines above for named hybrids and species as appropriate.

The Index of Garden Plants: The New Royal Horticultural Society Dictionary by Mark Griffiths (1994) and the American Horticultural Society A-Z Encyclopedia of Garden Plants (2004) are the acceptable references. Copies are available for reference at the SFS Office.

5. **PASSING:** Each exhibit must be passed by Division Passers before exhibit is accepted for judging. Passers determine exhibit conformity and eligibility.

6. EXHIBIT MATERIALS:

a. Permitted: Only naturally shed materials including antlers, feathers and skins, as well as bones and shells from non-endangered animals.

b. Not Permitted: Protected and endangered plant material (as listed on page 59) may not be exhibited unless grown by Exhibitor, with method of propagation/cultural requirements described on accompanying white, unlined 4" x 6" index card. Please be aware that some galax leaves could be harvested illegally. If you choose to use galax leaves in an exhibit, please ensure that you acquire them from a reputable supplier who has obtained them legally. Also: No live animals, fish, insects, or reptiles without prior permission from the SFS Committee or as stated in the pertinent Division Rules. No taxidermy or hides, except by special permission when pertinent to educational value of exhibit. No natural birds' nests or butterflies. **No artificial plant material.** No cut fruit, cut vegetables, dairy products or non-sealed (use shellac to seal) dough products. SFS Committee reserves the right to decide eligibility/suitability of any exhibit.

7. **JUDGING:** Exhibits will be judged according to the following schedule. **Not all Classes will be judged during both judging periods;** refer to Division Rules.

Division	Tuesday, February 7	Friday, February 10
Artistic Floral Design	10:00 a.m.	9:00 a.m.
Discovery	8:30 a.m.	-
Garden Design	10:00 a.m.	9:00 a.m.
Horticulture	10:00 a.m.	9:00 a.m.
Landscape	8:30 a.m.	-
Photography	10:00 a.m.	-
Professional Design	10:00 a.m.	9:00 a.m.
Youth	10:00 a.m.	9:00 a.m.

Judging is based on SFS 100 point scale, except where otherwise noted. Judges' decisions are final. During judging, only those actively involved in the judging process (Judges, Clerks, and appropriate Committee Chairs) are permitted in areas being judged.

GENERAL RULES (Continued)

8. **SWEEPSTAKES AWARDS:** Sweepstakes Awards are given to either individuals or groups based on the cumulative total of points awarded and are based on the specific guidelines for each award. See award descriptions on pages 38-44. All Entry Forms must include the name of the garden club to which the Exhibitor and Co-Exhibitor belong in order for the garden club to be considered for certain Sweepstakes Awards. Information about the size and location of the garden club may also be required. See page 43. The Point Scales for awarding Sweepstakes Awards are listed on page 44.

To qualify for **single Division** Sweepstakes Awards, Exhibitors must accumulate at least 10 points in the Division. To qualify for **multi-Division** Sweepstakes Awards, Exhibitors must accumulate at least 8 points in Horticulture **and** at least 8 points in Artistic Floral Design and/or Garden Design.

AWARDS CEREMONY: An Awards Ceremony for **all trophy winners** (except the Youth Division) will be held on Saturday, February 11 at 6:00 p.m. An Awards Ceremony for trophy winners in the Youth Division will be held on Sunday, February 12 at 5:00 p.m.

9. **RIBBONS AND CERTIFICATES:** Ribbons and Certificates from the first and second judging periods should be picked up in the applicable Division area during Show Removal Times only. (See box below in Rule 11.)
10. **EXHIBIT MAINTENANCE:** All exhibits must be maintained in Show condition. Any exhibit failing to conform will have all ribbons, trophies, and points withdrawn for that judging period. Also, the exhibit may, at the discretion of the SFS Committee, be removed from the Show floor. Exhibitors may groom and water only before 9:00 a.m. daily or by special permission of the SFS Committee.
11. **EXHIBIT REMOVAL:** No part of an exhibit may be removed by Exhibitor from the Show unless approved by SFS Class Advisor. **SIGNATURE REQUIRED FOR EACH EXHIBIT REMOVED IN ARTISTIC FLORAL DESIGN, GARDEN DESIGN, HORTICULTURE, PHOTOGRAPHY, AND PROFESSIONAL DESIGN DIVISIONS.**

REMOVAL TIMES: Thursday, February 9 6:45 p.m. - 9:00 p.m.
 Sunday, February 12 6:30 p.m. - 7:30 p.m.

12. **SHOW CLOSING:** The Show closes Sunday, February 12 at 6:00 p.m. No exhibit may be removed until 6:30 p.m. on Sunday, February 12. Removal of exhibits in the Landscape and Discovery Divisions must be in accordance with the Rules of those Divisions. Exhibitors in all other Divisions must make arrangements to remove their exhibits between 6:30 and 7:30 p.m. on Sunday, February 12. SFS is not responsible for items remaining on the Show Floor.
13. **SALES OF MERCHANDISE** are to be conducted during Show hours by Marketplace Exhibitors and SFS shops only. There will be no selling of plant material by Landscape or Discovery Exhibitors on the Show floor during the Show.
14. **SAFETY:** All backdrops and drapery must be fireproof. Exhibitors must guard against leaks or overwatering which can cause slippery floors. Spray painting and dry stone cutting are not allowed in the Georgia World Congress Center.
15. **LIABILITY:** SFS will exercise due caution in safeguarding exhibits, but cannot assume responsibility for damage or loss. **VALUABLES USED IN EXHIBITS SHOULD BE INSURED BY EXHIBITOR.**

GENERAL RULES (Continued)

- 16. LIMITATION OF SFS LIABILITY/WAIVERS:** In consideration for the benefits to Exhibitor provided in this Agreement and otherwise, Exhibitor hereby agrees to make no claim against the Atlanta Botanical Garden, Inc. (ABG) or Southeastern Flower Show, Inc. (SFS) or the Georgia World Congress Center (GWCC) and agrees that SFS shall not be liable for any injury or loss or damage whatsoever to Exhibitor, or its employees, agents, licensees and invitees or the property or business thereof caused by (a) any acts or omissions of any contractors or employees or agents or licensees of such contractors retained by SFS to perform services in connection with the Show or (b) fire, theft, destruction or any other occurrence not resulting from intentional misconduct on the part of SFS (or its employees acting in the scope of their employment), whether during Show hours or the periods designated for installation and removal of exhibits and not withstanding any negligence of SFS connected therewith. In addition, Exhibitor agrees to the use by SFS, for promotional and other purposes, of any and all photographs, slides, drawings or other visual representations of any exhibits entered in the Show, and Exhibitor hereby waives any claims or rights to any acknowledgments, credits or other interests in connection therewith.
- 17. INDEMNIFICATION FOR EXHIBITOR'S ACTS:** Exhibitor agrees to indemnify and hold harmless the Atlanta Botanical Garden, Inc., Southeastern Flower Show, Inc., Georgia World Congress Center and each of them, from any and all claims of liability whatsoever made by anyone for any loss, injury or damage to person or property, including death, arising out of the conduct of Exhibitor or its employees or agents, licensees and invitees and Exhibitor hereby agrees to defend the Atlanta Botanical Garden, Inc., the Southeastern Flower Show, Inc. and the Georgia World Congress Center against any such claims or liabilities and to reimburse them for all expenses, including without limitation all attorneys' fees, court costs, costs of litigation or settlement and any and all damages incurred in connection therewith.
- 18. RESERVATION OF RIGHTS:** The SFS has full authority to interpret, amend, and enforce all Show Rules and regulations as it may consider appropriate for the proper conduct of the Show.

ARTISTIC FLORAL DESIGN DIVISION RULES (Continued)

8. PASSING:

- All SFS forms (Title, Plant List and Statement of Purpose, if applicable) must be approved by Passers Chair and Botanical Reference Chair before the exhibit will be passed.
- Exhibits must be passed and ready for judging by 9:00 a.m., Tuesday, February 7 and by 8:30 a.m., Friday, February 10.
- Exhibitor must remain with exhibit until it has been passed.
- Once passed, only SFS Committee members may handle an exhibit during Show hours. However, Exhibitors should groom and water their plant material in accordance with Rule 9 below.

9. REQUIREMENTS:

- ALL EXHIBITS MUST BE CREATED ON SITE.
- All exhibits must be maintained and watered to meet Show standards. Exhibitor must replace any plant material not in Show condition with the same variety of material. Any exhibit failing to conform will have all ribbons, trophies, and points withdrawn for that judging period. Also, the exhibit may, at the discretion of the SFS Committee, be removed from the Show Floor. (See General Rule 10.) Exhibitors may groom and water before 9:00 a.m. daily or by special permission of the SFS Committee. *After judging, the SFS Committee reserves the right to alter designs that are not maintained in Show condition.
- All fresh plant material must be in water or be conditioned in such a way as to remain in pristine form while on exhibit.
- Any treating of plant material should be done with utmost discretion.
- Mechanics must not show unless they are an integral part of the design.
- Exhibit must be in proportion to the allotted space.
- Any exhibit not adhering to the Class Rules will remain in place without being passed or judged. Such exhibit will be marked "Not for Judging."

Permitted:

- Accessories, featured objects, stands and mats.
- Contrived flowers or plant forms made of recognizable plant material.
- Manipulation of plant material.
- Flatware, at Exhibitor's own risk.
- Special lighting. Must be approved by Class Advisor.
- Sealed dough products (shellac sealed).
- Treated and untreated dried plant material.

Not Permitted:

- Artificial plant material or dyeing of live plant material.
- Cut or sliced fruit or vegetables or dairy products.
- Plant material protruding beyond framed opening of niche.
- In Tables Class - liquid in glasses or opened beverage bottles or containers.
- Sterling silver.
- Live creatures including fish, birds, insects or reptiles.

- 10. END OF SHOW REMOVAL:** The Show closes at 6:00 p.m. Sunday, February 12, 2006. No exhibit may be removed from the Show Floor until 6:30 p.m. Please make arrangements to pick up your exhibit between 6:30 and 7:30 p.m. on Sunday, February 12; SFS cannot be responsible for items remaining on Show Floor.*

2006 ARTISTIC FLORAL DESIGN DIVISION POINT SCALES

Classes A06, A25

Design40
Originality30
Color & Harmony20
Theme Interpretation10

Classes A05, A10, A16

Design60
(overall20)
(artistic floral design40)
Creativity20
Distinction20

Classes A01, A02, A13, A14

Conformance (to schedule requirements)	20
Design (elements/principles)42
Artistic Concept (selection/organization) ..	.12
Expression (interpretation of Class)10
Distinction (marked superiority in all respects)16

*Indicates important change

2006 ARTISTIC FLORAL DESIGN DIVISION CLASSES

All Classes limited to six entries per judging period.

Exhibits in all Classes except Class A25, Judges' Challenge, are eligible, when specific award criteria are met, for the Garden Club of America Certificate of Excellence; the National Garden Clubs, Inc. Medal; the Peachtree, the Piedmont, and the Pine Tree Trophies; and SFS Maintenance Certificates. Other trophies are listed by the appropriate Class. See page 38 for a complete description of each award.

Note: Exact dimensions and additional information will be provided once entry is accepted.

CLASS A01 **Small Niche**

I MAESTRI ITALIANI **Italian Masters**

Advisor: Shirley Lovett 770-938-4723lovettscol@aol.com
Trophies: Foreman, Morrison

Interpret the genius of an ITALIAN MASTER PAINTER through a miniature floral design.

- Staged in black, square-framed niche. Interior may be painted or covered by Exhibitor. Niche lighting supplied by SFS. Square opening: 5.25" high x 5.25" wide. Bottom of opening approximately 52" from floor. Interior: 6" high x 6" wide x 6" deep.
- A copy of an Italian masterwork will be displayed on a nearby easel. Contact Class Advisor for copy of painting.
- Floral design not to exceed 5" in any direction.
- Use plant material that is fresh, dried, or a combination of both.
- Accessories permitted.
- Meets standards of National Garden Clubs, Inc. for entering and judging.

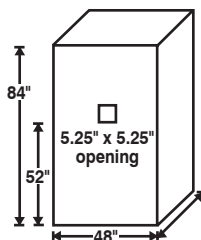

CLASS A02 **Medium Niche**

LA GROTTA ITALIANA **Italian Grotto**

Advisor: Edith Shepherd 404-329-9682evshepherd@yahoo.com
Trophies: Foreman, Morrison

Create a floral design in an ITALIAN GROTTA.

- Staged in black, oval-framed niche. Interior may be painted or covered by Exhibitor. Niche lighting provided by SFS. Oval opening: 24" high x 20" wide. Interior: 41" high x 24" wide x 16" deep. Bottom of opening is 45" from floor.
- Use plant material that is fresh, dried, or a combination of both.
- Accessories permitted.
- Meets standards of National Garden Clubs, Inc. for entering and judging.

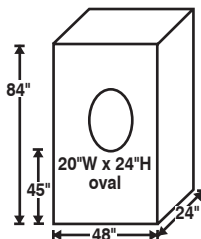

CLASS A05 **Tableau**

L'ESPERIENZA ITALIANA **The Italian Experience** **Available for Group Entry**

Advisor: Anna Collins 678-488-4025annacollins@comcast.net
Trophies: Magnolia, Reynolds

Let an ITALIAN EXPERIENCE inspire a Tableau.

- Floral design to be presented on a 36" square black laminate box, 30" high, with a 6" deep insert that can hold water, if desired. Interior is 35" square by 6" high.
- Contact the Class Advisor to name your Italian inspiration.
- Use plant material that is fresh, dried, or a combination of both.
- Accessories permitted, but floral design must predominate.

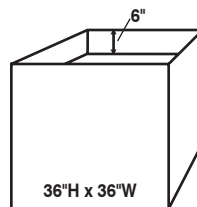

ARTISTIC FLORAL DESIGN DIVISION CLASSES (Continued)

CLASS A06

Mass

GLI DEI E LE DEE ROMANI

Roman Gods and Goddesses

Advisor: Jan Greene 404-845-0013G_JTroy@bellsouth.net

Trophy: Hastings

Interpret the primary emotion or characteristic of a ROMAN DEITY through a Mass arrangement using a monochromatic palette of plant material.

- Mass arrangement to be staged on green SFS pedestal, 37" high x 20" square. Design must be a minimum of 35" high including container. Backdrop is soft green and at least 8' tall.
- Contact the Class Advisor to claim your god or goddess.
- Requires all fresh plant material.

CLASS A10

Tables

DA "LA SCALA"

Opera

Available for Group Entry

Advisor: Jan Stair 404-352-4292JanStair@aol.com

Trophies: Cox, Davison, Hastings, Magnolia

Hit the high notes with a table setting inspired by ITALIAN OPERA.

- Staged on an 8' x 8' riser, 6" high, viewed from all sides. SFS provides table, 36" in diameter and 29" high. Exhibitor may provide own table.
- Claim one of the following operas, or name your own, by contacting the Class Advisor: Puccini's *Turandot*, *La Boheme*, *Madame Butterfly* or *Tosca*; Verdi's *Rigoletto*, *La Traviata*, *Aida*, or *Falstaff*; Rossini's *The Barber of Seville*; Bellini's *Norma*; Leoncavallo's *Pagliacci*; or Donizetti's *Lucia de Lammermoor*.
- Requires all fresh plant material in the floral design, which must predominate.
- Accessories are permitted, including multiple containers and two chairs. Place settings required. Table requires cloth to floor.

CLASS A13

Cubes

LA LETTERATURA

Literature

Advisor: Cookie Roland 770-972-0219 . . .CookieTom@mindspring.com

Accept the challenge of ITALIAN LITERATURE by interpreting a passage from Dante's INFERNO.

- Staged in an open high-gloss red cube 36" square, set on one of its corner points. Cube is attached to a 36" square black pedestal, creating a diamond shape viewable from all sides. Height of cube, point to point, is 54 inches. Design may be hung from hook at top or rise from pedestal, but is not limited to these two options.
- Contact the Class Advisor to name and claim your Canto lines.
- Use plant material that is fresh, dried, or a combination of both.
- Meets standards of National Garden Clubs, Inc. for entering and judging.

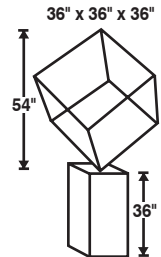

ARTISTIC FLORAL DESIGN DIVISION CLASSES (Continued)

CLASS A14 Mannequins

LA MODA Fashion

Advisor: Betty Trankina 770-410-5819bhtran140@yahoo.com

Look to ITALIAN FASHION to inspire floral attire for a wire mannequin.

- Floral design to be presented on a life-sized wire mannequin torso supplied by SFS. Design to be viewed from all sides. Mannequin staged on a small platform, 6" high x 24" x 22". Platforms are taupe, but may be painted color of choice.
- Contact the Class Advisor to arrange viewing of wire mannequin.
- Use plant material that is fresh, dried, or a combination of both.
- Accessories permitted.
- Meets standards of National Garden Clubs, Inc. for entering and judging.

CLASS A16 Vignette

AL CINEMA At the Movies Available for Group Entry

Advisor: Kay Ottley 404-876-7749KayOttley@mindspring.com
Trophies: Davison, Magnolia, Reynolds

Direct your own movie scene inspired by ITALIAN CINEMA and present it as a staged vignette. Movie may be about Italy or filmed by an Italian director.

- Staged on a platform 4" high x 10' wide x 8' deep, against a back wall 8' high.
- Contact Class Advisor to name and claim an Italian movie.
- Requires all fresh plant material in the floral design, which must predominate.
- Accessories are permitted and encouraged. Multiple containers allowed.

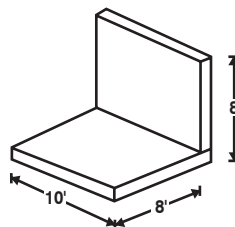

CLASS A25 Judges' Challenge

DISEGNO INTERPRETATIVO Interpretive Design

Advisor: Claire Griffith 404-350-0763Claire.Griffith@comcast.net

Judges will be challenged to interpret a work of art by a famed Italian artist.

- Staged on a pedestal 30" high x 18" square.
- Open to out-of-town judges only.
- All materials, tools, and equipment are provided by SFS.
- \$45 entry fee.

GARDEN DESIGN DIVISION

Co-ChairsStephanie Nelson . .770-594-6820hnelson01@bellsouth.net
 Gloria Ward770-956-7734

Entry ChairAmy Wood404-352-1385 . .amy.wood@alexanderkey.com

AdvisorsAnna Bradley404-256-4704annawbradley@aol.com
 Cappa Woodward . .404-841-6446 .cappawoodward@earthlink.net

2006 GARDEN DESIGN DIVISION RULES

1. **All SFS General Rules apply.** (See pages 7-10.) Detailed Class Rules and Specifications will be provided with entry acknowledgment.
2. **ELIGIBILITY:** Open to all Exhibitors (e.g., garden clubs, design students, plant societies, individuals 18 years or older). No business names or advertisements may be used on the Show Card or exhibit. Exhibitors who enter the Professional Design Division are not eligible to enter the Garden Design Division or the Artistic Floral Design Division in 2006 or in 2007.
3. **ENTRIES:** Mailed entries may be submitted beginning September 15, 2005. You may use the 2006 Garden Design Division Entry Forms found on pages 47 and 48 of this Guide or you may download Entry Forms from the SFS website at www.flowershow.org. All entries must be **received** by Thursday, January 19, 2006.
 - Entries will be accepted in the order received.
 - Exhibitor may enter one time in each Class per judging period.
 - Classes G07, G08, G09, and G11 are available for Group Entry as well as Individual Entry. Class G04 is limited to Individual Entry only (see General Rule 2).
 - ANY EXHIBITOR UNABLE TO EXHIBIT MUST FIND A SUBSTITUTE. All substitutes **MUST BE APPROVED** by a Garden Design Chair.
 - * The following Class meets the standards of The National Garden Clubs, Inc. for entering and judging: G04, Pot et Fleur.
4. **CHECK-IN:** Class Advisors will provide entry, unloading and parking instructions to all Exhibitors.
5. **STATEMENT OF PURPOSE AND TITLE:** A title and a brief explanation of your inspiration or interpretation (Statement of Purpose) of the Garden Design Class theme (three sentences or less) is required by January 19, 2006. You may use the form on page 55 of this Guide, or you may download the form from the SFS website at www.flowershow.org. No duplication of theme interpretation permitted in any Class.
6. **A PLANT LIST** keyed to a Diagram of the exhibit is required at the time of installation. The Diagram of the plant exhibit, which may be drawn at the time of installation, must be on an 8.5" x 11" plain white piece of paper. Plant List must include both botanical and common names, and must state the season and exposure. You may use the form on page 59 of this Guide, or you may download the form from the SFS website at www.flowershow.org.
7. **INSTALLATION:** The exhibit Title, Plant List, Diagram, and Statement of Purpose must accompany each exhibit. Entries installed and passed only during the following times:

First Installation:	Sunday, February 5By arrangement with Class Advisor Monday, February 64:00 p.m. - 8:00 p.m.
Second Installation:	Thursday, February 97:00 p.m. - 8:30 p.m.

8. **PASSING:**
 - All SFS forms (Title, Plant List, Statement of Purpose, and Plant Diagram if applicable) must be approved by Passers Chair and Botanical Reference Chair before the exhibit will be passed.
 - Exhibits must be passed and ready for judging by 8:00 p.m. on Monday, February 6, and by 8:30 p.m. on Thursday, February 9.
 - Exhibitor must remain with exhibit until it has been passed.
 - Once passed, only SFS Committee members may handle an exhibit during Show hours. However, Exhibitors should groom and water their plant material before and after Show hours.
9. **REQUIREMENTS:**
 - **Final design must be created on site.**
 - **Only fresh, rooted plant material may be used in the design (with the exception of Class G04 Pot et Fleur in which some fresh-cut plant material is required.)** Dried plant material is not permitted in the planted design. However, organic plant material

* Indicates important change.

2006 GARDEN DESIGN DIVISION RULES (Continued)

(such as moss, dried leaves, pinecones, sweet gum balls and woodchips) or inorganic material (such as gravel, glass, or paper products) may be used on the container or platform as a decoration, cover-up or structural component.

- **Plant material must reflect a particular season and exposure.**
- Mechanics must not show unless they are an integral part of the design. No recorded sound effects are permitted.
- Exhibit, including all support structures, must fit within the allotted space.
- All exhibits must be maintained and watered to meet Show standards. Exhibitor must replace any plant material not in Show condition with the same variety of material. Any exhibit failing to conform will have all ribbons, trophies and points withdrawn for that judging period. Also, the exhibit may, at the discretion of the SFS Committee, be removed from the Show Floor. (See General Rule 10.) Exhibitors may groom and water before 9:00 a.m. daily or by special permission of the SFS Committee. *After judging, the SFS Committee reserves the right to alter designs that are not maintained in Show condition.
- Any exhibit not adhering to the Class Rules will remain in place without being passed or judged. Such exhibit will be marked "Not for Judging."
- Accessories are permitted, but at Exhibitor's own risk.

- 10. END OF SHOW REMOVAL:** The Show closes at 6:00 p.m. Sunday, February 12, 2006. No exhibit may be removed from the Show Floor until 6:30 p.m. Please make arrangements to pick up your exhibit between 6:30 and 7:30 p.m. on Sunday, February 12; SFS cannot be responsible for items remaining on Show Floor.

2006 GARDEN DESIGN DIVISION POINT SCALES

Classes G07, G08, G09, G11

Design and Creativity	35
Selection/Use of Plants	.30
Condition of Plant Material	.20
Theme Interpretation	.10
Labeling & Cultural Information	.5

Class G04

Conformance (to schedule requirements)	.20
Design (elements/principles)	.42
Artistic Concept (selection/organization)	.12
Distinction (marked superiority in all respects)	.16
Expression (interpretation of Class)	.10

All Garden Design exhibits, if merited, will be eligible for the Henderson, McCarty, Piedmont, and Smith trophies and for the SFS Maintenance Certificates. Other trophies are listed by appropriate Class.

2006 GARDEN DESIGN DIVISION CLASSES

All Garden Design exhibits, if merited, will be eligible for the Henderson, McCarty, Piedmont, and Smith trophies and for the SFS Maintenance Certificates. Other trophies are listed by appropriate Class.

La Piazza

Daily life revolves around the heart of the Italian village, "La Piazza." The ancient buildings with their doorways and balconies provide a picturesque backdrop for frequent village markets and festivals. The central fountain and the gardens provide a serene setting for the daily "passeggiata" or evening stroll. Create scenery typical of "La Piazza."

CLASS G04

VASO E FIORE

Pot et Fleur

Individual Entry

Advisor: Mary Ann Griffith 404-705-9954mhgriff@comcast.net

Trophy: Ivy

Create a garden in a terra cotta container.

- Staging provided by SFS will be a black pedestal 16" square and 32" high.
- Terra cotta container, of appropriate size to pedestal, provided by Exhibitor.
- Design must include two or more rooted plants growing in soil and fresh-cut plant material.
- May include naturally occurring wood, moss, or rock as top dressing.
- Will be viewed from all sides.
- Limited to 6 entries.
- Meets standards of National Garden Clubs, Inc. for entering and judging.

2006 GARDEN DESIGN DIVISION CLASSES (Continued)

CLASS G07
Small Platform

VITA FRA LE ROVINE
Life Among the Ruins
Available for Group Entry

Advisor: Sheila Johnson 770-951-8449 . . . sheilajohnson@bellsouth.net

Create a living composition incorporating a ruin provided by Exhibitor.

- Staging provided by SFS will be a 4' x 4' platform, 24" high.
- Must include only rooted plants growing in soil.
- May include accessories.
- Will be viewed from all sides.
- Limited to 4 entries.

CLASS G08
Large Platform

IL GIARDINO ITALIANO DI VIGNETTE
Italian Garden Vignette
Available for Group Entry

Advisor: Paule Chalmers 770-436-3647 . . . pchalmer@mindspring.com

Create a garden setting incorporating a garden element such as an obelisk or statue.

- Staging provided by SFS will be a 6' x 8' platform, 6" high.
- Garden element provided by Exhibitor must be at least 4' tall.
- Must include only rooted plants growing in soil.
- May include accessories and hardscape.
- Will be viewed from all sides.
- Limited to 4 entries.

CLASS G09
Balcony

IL BALCONE DI UN ITALIANO FAMOSO
Balcony of a Famous Italian
Available for Group Entry

Advisor: Karen Clydesdale 770-643-0390 karenclydesdale@bellsouth.net

Stage a scenic display of plants in containers on a balcony that might belong to a famous Italian. Diagram of balcony provided upon acceptance of entry.

- Balcony floor is 4' x 8' in front of 3' x 6'8" glass door. Height from balcony floor to balcony railing is 30". The balcony is elevated 28" from the exhibit hall floor. SFS will provide balcony units and draping from balcony floor to exhibit hall floor.
- Containers provided by Exhibitor.
- Must include only rooted plants growing in soil. Plant material may extend over balcony edges.
- May include accessories.
- Will be viewed from front and sides.
- Limited to 4 entries.

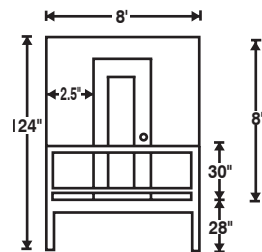

2006 GARDEN DESIGN DIVISION CLASSES (Continued)

CLASS G11 ERBE FRESCHE PER LA CUCINA ITALIANA

Doorway

Fresh Herbs for the Italian Cook

Available for Group Entry

Advisor: Margo Dexter 404-266-9449 mtdexter@bellsouth.net

Create an Italian kitchen herb garden in containers as an entrance to a free-standing door and, using stone or stone product, stage a floor on which to place the containers.

- The space for the flooring in front of the door must extend 2' (but no more than 2') on either side of the door and have a depth of 30" (but no more than 30"). Doors sit on a platform 6" above the level of the exhibit hall floor. Each of the four 3' x 6'8" doors will be painted a different color, representing the regions of Italy: Amalfi Coast, blue; Sicily, olive green; Tuscany, mustard blossom; and Chianti, wine. Choice of color is available in order of entry. Painted doors are provided by SFS.
- Containers provided by Exhibitor.
- Must include only rooted plants growing in soil.
- May include accessories.
- Will be viewed from front and sides.
- Limited to 4 entries.

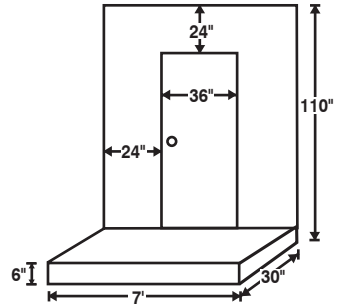

A MEETING OF GARDEN DESIGN EXHIBITORS

WILL BE HELD ON

THURSDAY, JANUARY 12, 2006

AT 10:00 a.m.

LOCATION: SFS Office, Suite 400, 1705 Commerce Drive, N.W.

Atlanta, GA 30318

Exhibitors will be able to ask questions about their designs, entry, and staging.

HORTICULTURE DIVISION

Co-Chairs	Denise Caffrey404-352-1669	consulaw@aol.com
	Emily Johnson404-816-8087c6120@aol.com
Entry Chair	Darlene Palmer770-388-9020trango@bellsouth.net
Installation Chair	Lamar Miller404-843-9216lwm377@mindspring.com
Nomenclature Chair	Carol Denhof404-591-1719	cdenhof@atlantabotanicalgarden.org
Reference Chair	Clark Robinson404-966-5588	wcrobertson@mindspring.com
Show Card Chair	Katie Lindquist404-237-0546klind13@bellsouth.net
Staging Chair	Barbara Fricker770-641-9060barbfricker@mindspring.com
Advisors	Virginia Almand404-355-0736valmand@bellsouth.net
	Havalyn Hensley404-307-4723hhensley@na.cokecece.com
	Dollie Swanson770-435-2343diddley1@bellsouth.net

Why Enter Online?

- Horticulture Division Exhibitors can enter their exhibits online.
- Online entry saves everyone time and money, and of course...trees.
- It's easy; all you need is access to the internet.
- Enter in the comfort of your home or office.
- Once you enter, you can add, change or delete exhibit details.
- To enter online, go to www.flowershow.org and follow the instructions.

2006 HORTICULTURE DIVISION RULES

1. **All SFS General Rules apply.** (See pages 7-10.)
2. **ELIGIBILITY:** Open to Exhibitors whose principal source of income does not come from growing or selling plant material eligible for Class entered, except that such Exhibitors may enter Classes H16 and H20.
3. **POSSESSION:** Exhibits must have been in Exhibitor's possession at least 90 days before the Show (November 10, 2005), except that Classes H17 and H28 require at least 6 months' possession.
4. **ENTRIES:**
 - a. Entries made prior to February 3, 2006, are "Early Entries": Entries may be submitted online or by mail prior to the Early Entry deadline date of February 3, 2006. Entering your exhibits prior to the Early Entry deadline reserves space for them and is the simplest and fastest way to enter an exhibit. There is no limit to the number of exhibits you may enter and there is no penalty if not actually installed. If you make more than one entry in any Class or Subclass, each entry must be a different species or cultivar.
 - **Online** entries may be submitted by going to the Southeastern Flower Show website: www.flowershow.org and following the instructions.
 - **Mailed** entries may be submitted using the 2006 Horticulture Division Entry Form found on page 49 of this Guide. Mailed entries must be received by February 3, 2006.
 - **No faxed or e-mailed entries will be accepted.**
 - b. **Entries made after February 3, 2006, are "On-Site Entries":** The only times available to submit entries after February 3, 2006, are during the delivery/installation/registration periods as stated in Rule 5 below. Please note: due to limited availability of display space, acceptance of On-Site Entries may be limited.
 - c. Classes H07 and H08 meet the standards of National Garden Clubs, Inc. for judging and entering.

2006 HORTICULTURE DIVISION RULES (Continued)

Contact the Horticulture Division Entry Chair for additional entry information.

5. **DELIVERY/INSTALLATION PERIODS:** There will be two delivery/installation periods for the Show.
- The first delivery/installation period for Early Entries and On-Site Entries is **Monday, February 6, 2006**, from 4:00 p.m. until 8:00 p.m. Entries for all Horticulture Classes may be installed during the first period. Subject to the provisions of General Rule 10 (Exhibit Maintenance), all exhibits installed during the first period remain on display throughout the Show. However, exhibits in Classes H04, H05, H07, H08, H12 and H20 may be removed by the Exhibitor during the second period described below.
 - The second delivery/installation period for Early Entry and On-Site Entry is **Thursday, February 9, 2006**, from 7:30 p.m. - 9:00 p.m. Only entries for Classes H04, H05, H07, H08, H12 and H20 will be accepted.

6. **DELIVERY/INSTALLATION/REGISTRATION PROCESS:**

- Delivery to the GWCC:** Go to the website: www.flowershow.org for directions or refer to the map and directions enclosed in this Guide. Exhibitors enter Building C from Northside Drive. Because no parking is available at the main entrance and unattended cars will be towed, exhibits must be unloaded quickly. We encourage you to carpool. Assistance with unloading will be available. An attended holding area will be available at the entrance for Exhibitors to temporarily place their exhibits while vehicles are being parked. Once inside the Hall, an SFS volunteer will direct you to the Registration area.
- Identification Card:** All exhibits must be accompanied by **two** 4" x 6" white index cards with the following information clearly printed or typed in black waterproof ink: One side of each card should contain Exhibitor's name, address, phone number, county, garden club or plant society (if applicable). Stick-on address labels or waterproof stamps may be used. The other side of each card should contain the Class number (in upper left-hand corner) and the exhibit's botanical and common name. The acceptable references are: The New Royal Horticultural Society Dictionary by Mark Griffiths (1994) and the American Horticultural Society A-Z Encyclopedia of Garden Plants (2004). Copies are available for reference at the SFS Office.

See example below.

FRONT	BACK
Jane Doe 24 Pine St. Atlanta, GA 30300 404-123-4567 County: Fulton Dirt Diggers Garden Club	H14.02 Hedera helix 'Needlepoint' English Ivy

- Culture Card:** An additional white 4" x 6" index card may be required containing plant/cultural information. Please refer to specified requirements for each Class.
- Collection Card:** An additional card is required for plant collections. A numbered Plant List and keyed Diagram or coordinating stickers/labeling system are required for plant collections. **Exhibitors must provide labeling materials.**

2006 HORTICULTURE DIVISION RULES (Continued)

7. IMPORTANT INFORMATION:

- a. **Foliage:** Plants exhibited primarily for effective foliage shall be classed as such. Flowers on such plants are accepted.
- b. **Container Dimensions:** Refers to largest inside measurement at top; rectangular containers measured on diagonal; globes measured at widest diameter; strawberry jars measured by height. Because container sizes from different sources are not uniform, a 1/2" leeway will be given. For example, 7½" and 8½" will be accepted for an 8" pot. No further leeway will be given.
- c. **Container:** Container should be clean, free of chemical deposits, and in proportion to plant material. H16, H17, H20, H24, H28 and H29 are permitted to have algae, moss and other signs of age. Double potting is allowed but must not show. Simple, unpainted, terra-cotta clay pots are strongly recommended. Terra-cotta-colored plastic pots, dark green rigid plastic pots, and lightweight fiberglass pots are recommended for heavy plants. Wire baskets are allowed; however, wicker or plastic baskets are not acceptable. White or brightly colored pots are not acceptable (Exception: H13). Fiber pots and ridged containers (including black or green nursery "production" pots) are not acceptable.

Remember: Plants will be moved during staging. All containers must be strong enough to withstand being moved. If your plant is in a delicate or awkward pot, we suggest that you repot it before bringing it to the Show.

- d. **Accessories and Topdressing:** No man-made accessories allowed (Exception: H28). Natural topdressing allowed if harmonious with plant and container [e.g., woodland moss or bark for shade-loving plant(s) or small rock or sand for sun-loving plant(s).]
- e. **Passing:** In order to be passed, exhibit must meet Class requirements and must be:
- correctly identified
 - healthy and in good condition
 - in clean, properly-sized containers
 - free of insects and disease

Passers' decisions are final. Once passed, exhibit may be touched ONLY by SFS Committee. Any special care instructions must accompany your exhibit in writing. Please call your Class Advisor for any special needs.

8. **STAGING:** Classes may be divided or combined at discretion of SFS Committee or judges.

9. **JUDGING:** Based on conformance to SFS Exhibitor's Guide and the following horticultural definitions:

- Cultural Perfection - well-grown, vigorous, healthy, good color, texture and form.
- Distinction - marked superiority in all respects: originality, proportion, aesthetic appeal.
- Floriferousness - abundance of flowers.
- Grooming - cleanliness of foliage, flowers and container; minimum visible support; appropriate pruning. No leaf polish.
- Inflorescence - size, quality and color of bloom; trueness to type.
- Labeling - proper identification of plants.
- Maturity - degree of fullness or perfection of development.
- Plant Information - when required, a brief, factual explanation on white 4" x 6" index card.

10. **REMOVAL:** See General Rules 8, 9, 10 and 11. Horticulture Division Exhibitors will be given a receipt at the time of installation which must be presented to remove your exhibit from the Show.

11. **END OF SHOW REMOVAL:** The Show closes at 6:00 p.m. Sunday, February 12, 2006. No exhibits may be removed from Show floor by Exhibitor until 6:30 p.m. on Sunday. Exhibitors must make arrangements to pick up exhibits between 6:30 and 7:30 p.m. on Sunday, February 12. SFS cannot be responsible for items remaining on the Show Floor.

2006 HORTICULTURE DIVISION CLASSES

Exhibits in all Classes are eligible, if merited, for the Bulkley Medal, Certificate of Excellence from the Garden Club of America, and the National Garden Clubs Medal. All classes are eligible for the Northwood Trophy except H20 (Pro's Corner) and some designated orchids. SFS Awards of Excellence are given for best in Class where no specific Class trophy is given. Specific trophies are listed with individual Classes.

Note: Classes H01 (All in the Family), H03 (Bromeliads), H06 (On a Rock, Under Glass or In a Cage), H09 (Double Your Pleasure), H10 (Conifers), H15 (Old Friends), H19 (Plants of the World), H21 (Strawberry Jars), H23 (Tiny Treasures), H25 (Trough Gardens), H26 (Birds Eye View) and H27 (The Men's Room) are not being presented at the 2006 Show.

CLASS H02 **BEGONIA CLASSES**

Advisors: Johnnie Hadley 770-907-7330chocolatejrh@yahoo.com
Willie Mae McDaniel 404-289-9764

Trophies: Ballard, Harris, Species

Note: Hort. Rule 6d.

H02.01	Begonia, flowering. Pot: 4" or under.	Flowering Point Scale:
H02.02	Begonia, flowering. Pot: over 4" to 8".	Cultural Perfection40
H02.03	Begonia, flowering. Pot: over 8".	Condition30
H02.04	Begonia, foliage. Pot: 4" or under.	Bloom Quality10
H02.05	Begonia, foliage. Pot: over 4" to 8".	Bloom Quantity10
H02.06	Begonia, foliage. Pot: over 8".	Growing Difficulty10
H02.07	Begonia(s) grown in contained atmosphere. Single species or cultivar.	Foliage Point Scale:
H02.08	Begonia(s) grown in contained atmosphere. More than one species or cultivar.	Cultural Perfection50
		Condition40
		Growing Difficulty10

CLASS H04 **BULB CLASSES**

Advisors: Brenda Dreyer 404-352-0858B_Dreyer@bellsouth.net
Nancy Balentine 404-875-4410 . . .abalentine@bellsouth.net

Trophies: Ballard, Habersham, Species

No limit to number of bulbs in pots unless specified. All bulbs (except Bulb Garden) must be shown in pot in which grown. Pre-enter bulbs both entry times, but bring when bulbs are in Show Condition. Natural topdressing allowed; no Spanish moss. Discreet staking encouraged and may be required at time of entry. Contact advisors for "Forcing Instructions" and bulb sources. **Note: Hort. Rule 6d, General Rule 3.**

H04.01	Bulb, Novice, any Narcissus, 8"pot.	H04.01-H04.13 Point Scale:
H04.02	Bulb, Novice, any Tulipa, 8" pot.	Exhibit as a Whole40
H04.03	Bulb, Novice, any Hippeastrum (Amaryllis). A single bulb.	Bloom40
		Foliage10
H04.04	Bulb, Narcissus 'Bridal Crown.' 8" pot.	Stems10
H04.05	Bulb, Narcissus 'Carlton.' 8" pot.	H04.14 Point Scale:
H04.06	Bulb, Tulipa 'Apricot Beauty.' 8" pot.	Exhibit as a Whole40
H04.07	Bulb, Tulipa 'Calgary.' 8" pot	Bloom35
H04.08	Bulb, Hyacinthus orientalis 'Blue Jacket.' 8" pot.	Foliage10
H04.09	Bulb, any Crocus. 6" pot.	Stems10
H04.10	Bulb, any Iris. 6" pot.	Suitable Labeling5
H04.11	Bulb, any Muscari. 6" pot	
H04.12	Bulb, any Hippeastrum (Amaryllis).	
H04.13	Bulb, any other bulb(s), tuber(s) or rhizome(s) not listed above.	
H04.14	Bulb Garden: Any combination of bulbs in a pot 12" or under.	

2006 HORTICULTURE DIVISION CLASSES (Continued)

CLASS H05 CAMELLIA CLASSES

Advisors: Jo Ann Hagaman 404-876-2606
 Jim Pruckler 770-493-4066 j.pruckler@att.net
 Trophies: Hodges, Paullin, Species

Cut specimens only; containers provided by SFS.

H05.01	Camellia miniature, indoor.	H05 Point Scale:	
H05.02	Camellia miniature, outdoor.	Form	.20
H05.03	Camellia japonica, indoor.	Color & Marking	.20
H05.04	Camellia japonica, outdoor.	Size	.20
H05.05	Camellia reticulata.	Texture, Substance, and Condition	.20
H05.06	Camellia hybrid, indoor.	Distinction	.15
H05.07	Camellia hybrid, outdoor.	Foliage	.5

CLASS H07 CUT SPECIMENS – HERBACEOUS CLASSES

Advisors: Ann Harris Howington 404-233-7076
 John Lipscomb 770-475-4243

Trophies: Herb Soc., Johnson, Species

Exhibit must be grown by Exhibitor. Container and wedging material provided by SFS. Single stem only. If specimen is grown outside Zone 7B, Exhibitor should note this on accompanying 4" x 6" index card. Meets Standards of National Garden Clubs, Inc. for entering and judging.

Note: Hort. Rule 6c.

H07.01	Herbaceous, annual or biennial.
H07.02	Herbaceous, perennial.
H07.03	Herbaceous, Narcissus.
H07.04	Herbaceous, any other bulb, corm, rhizome or tuber.
H07.05	Herbaceous, any stem of winter interest.
H07.06	Herbaceous, forced.

H07.01-H07.04 Point Scale:	H07.05 Point Scale:	H07.06 Point Scale:
Cultural Perfection45	Cultural Perfection40	Cultural Perfection45
Condition25	Degree of Interest35	Difficulty of Forcing40
Distinction15	Distinction25	Distinction10
Grooming15		Grooming5

CLASS H08 CUT SPECIMENS – WOODY CLASSES

Advisors: Sally Griffith 770-977-4031
 Trophies: Herb Soc., Hodges, Johnson, Species

Exhibit must be grown by Exhibitor. Container and wedging material provided by SFS. Single stem only. If specimen is grown outside Zone 7B, Exhibitor should note this on accompanying 4" x 6" index card. Exhibits can be no more than 24" tip to tip. Meets standards of National Garden Clubs, Inc. for entering and judging. **Note: Hort. Rule 6c.**

H08.01	Woody, tree.
H08.02	Woody, shrub.
H08.03	Woody, vine.
H08.04	Woody, any stem of winter interest.
H08.05	Woody, forced.

H08.01-H08.03 Point Scale:	H08.04 Point Scale:	H07.06 Point Scale:
Cultural Perfection45	Overall Effect40	Cultural Perfection45
Condition25	Degree of Interest35	Difficulty of Forcing40
Distinction15	Distinction25	Distinction10
Grooming15		Grooming5

2006 HORTICULTURE DIVISION CLASSES (Continued)

CLASS H11 FERN CLASSES

Advisor: Johnnie Berry 404-691-8902
 Emily Johnson 404-816-8087c6120@aol.com
 Trophies: Lyon, Species

- H11.01 Fern, Novice. (See General Rule 3.)
- H11.02 Fern, hanging container.
- H11.03 Fern, not hanging container.

H11 Point Scale:
 Cultural Perfection60
 Form (according to variety) .20
 Distinction20

**CLASS H12 FROM THE OUTSIDE IN...
 Tea with Mussolini**

Advisor: Nancy Campbell 404-266-1477
 Trophies: Ballard, Hodges, SFS, Smith

A collection of 3 or more different species (multiple stems of each species permitted) cut from Exhibitor's own garden and attractively arranged in an Italian-made container or one that suggests something Italian. Specimens should not be over 24" from tip to tip.

Note: Hort. Rule 6d applies, but a keyed Diagram may be supplied in lieu of labels.

H12 Point Scale:
 Overall Effect30
 Cultural Perfection30
 Variety15
 Distinction15
 Suitable Labeling10

CLASS H13 GESNERIAD CLASSES

Advisors: Mel Landry 770-592-6540melsviolets@aol.com
 Kathy Spissman 770-939-5289 .mrsstrepstrels@comcast.net
 Trophies: SFS, Species

- H13.01 Gesneriad, Saintpaulia, variegated standard.
- H13.02 Gesneriad, Saintpaulia, greenleaf standard or any other standard.
- H13.03 Gesneriad, Saintpaulia, miniature and semi-miniature.
- H13.04 Gesneriad, Saintpaulia, trailers.
- H13.05 Gesneriad, Streptocarpus.
- H13.06 Gesneriad, any other, blooming.
- H13.07 Gesneriad, any other, foliage.

H13.01-H13.04 Point Scale:	H13.05-H13.06 Point Scale:	H13.07 Point Scale:
Symmetry /Form25	Cultural Perfection40	Cultural Perfection40
Condition25	Condition35	Ornamental Value
Quantity of Bloom25	Quantity of Bloom25	(shape, texture, color) ...35
Size & Type of Bloom ..15		Grooming25
Color of Bloom10		

CLASS H14 IVY CLASSES

Advisor: Anna Crevier 770-466-3603loganna@bellsouth.net
 Leonie Hardie 404-373-1112wlhardie@yahoo.com
 Trophies: Moran, Species

- H14.01 Ivy, curly.
- H14.02 Ivy, bird's foot.
- H14.03 Ivy, fan shape.
- H14.04 Ivy, heart shape.
- H14.05 Ivy, variegated.
- H14.06 Ivy, miniature.
- H14.07 Ivy, any other.

H14 Point Scale:
 Cultural Perfection50
 Distinction35
 Grooming & Suitable
 Labeling15

2006 HORTICULTURE DIVISION CLASSES (Continued)

CLASS H16 ORCHIDS

Advisors: Roy Harrow 770-434-8059roy.harrow@assurant.com
 Danny Lentz 770-640-0112
 Trophies: Ellenberg, Species

Orchids will be judged during the first judging period only.

Plants must be in Show condition to be passed. Entries in all orchid Subclasses will be judged for ribbons using the American Orchid Society (AOS) Point Scale and will also be judged for AOS Awards, unless marked "not for AOS judging." Requirements for AOS awards: 1. Any plant previously entered for judging in an AOS Show on the same blooming is not eligible for an AOS award at the 2006 SFS and should be marked "not for AOS judging" (Individual flowers from sequentially flowering species and hybrids are not considered to be the same blooming.); 2. An Exhibitor winning an AOS award at the 2006 SFS agrees to pay a \$40 processing fee to AOS; 3. Points will be deducted for incomplete labeling.

H16.01	Orchid, Cattleya and Allied Genera.	H16 Point Scale:
H16.02	Orchid, Cymbidium and Allied Genera.	Color of Flowers30
H16.03	Orchid, Dendrobium and Allied Genera.	Form of Flowers30
H16.04	Orchid, Epidendrum and Allied Genera.	Size of Flowers10
H16.05	Orchid, Oncidium and Allied Genera.	Habit & Arrangement of
H16.06	Orchid, Paphiopedilum and Allied Genera.	Inflorescence10
H16.07	Orchid, Phalaenopsis and Allied Genera.	Floriferousness10
H16.08	Orchid, Phragmipedium and Allied Genera.	Substance and Texture10
H16.09	Orchid, Vanda and Allied Genera.	
H16.10	Orchid, any other species/variety/hybrid not included above.	

CLASS H17 PAR

Advisor: David Mellard 404-498-0443dmellard@cdc.gov
 Trophies: Ballard, Herb Soc., Morrison, Smith,
 Species, Swanson

A container-grown exhibit of outstanding horticultural merit (a single plant or a collection) which is not eligible for other Classes. To be judged on par means to be judged against perfection rather than against other exhibits. **At least 6 months' possession required.** Please state space required for exhibit on Entry Form. **Note: Hort. Rules 3, 6d and 7c.**

CLASS H18 PARENT AND OFFSPRING

Advisor: Havalyn Hensley 404-307-4723 . .hensley@na.cokecce.com
 Trophies: Herb Soc., Hodges, SFS Lyon, SFS Species

Multiple offspring permitted. Shown in separate containers, accompanied by a white 4" x 6" index card stating method and date of propagation. Please state space required for exhibit on Entry Form. **Note: Hort. Rule 6c.**

H18 Point Scale:

Cultural Perfection50
Distinction20
Propagation Difficulty20
Propagation Information10

2006 HORTICULTURE DIVISION CLASSES (Continued)

CLASS H20 PRO'S CORNER

Advisor: Sharon Flores 912-638-2412 . . .sharon.flores@earthlink.net
Trophies: Ballard, Ellenberg, Hodges, Lyon, SFS, Smith, Species

Plant(s) or a single stem cut from a professional gardener's private collection to be judged against perfection rather than against other exhibits. SFS will supply container and wedging material for single cut stems. Please state space required for exhibit on Entry Form. **Note: Hort. Rules 6d and 7c.**

- H20.01 Pro's Corner, cut specimen
- H20.02 Pro's Corner, container-grown plant(s)
- H20.03 Pro's Corner, Cut specimen, not limited to private collections, not judged.
- H20.04 Pro's Corner, Container-grown plant(s), not limited to private collections, not judged.

2006 HORTICULTURE DIVISION CLASSES (Continued)

CLASS H22 SUCCULENTS

Advisor: Kara Ziegler 404-591-1718 kziegler@atlantabotanicalgarden.org
 Trophies: Ballard, Herb Soc., SFS, Smith, Species

Note: Hort. Rule 6d.

- H22.01 Succulents, Crassula Family, Old World.
- H22.02 Succulents, Crassula Family, New World.
- H22.03 Succulents, Euphorbia Family, Madagascar endemics.
- H22.04 Succulents, Euphorbia Family, Non-Madagascar endemics.
- H22.05 Succulents, Aloe Family.
- H22.06 Succulents, Agave Family.
- H22.07 Succulents, any family other than Crassula, Euphorbia, Aloe or Agave.
- H22.08 Succulents, Caudiciform, dormant and active allowed.
- H22.09 Succulents, any exhibits grown outside in Zones 5 through 8A that have historically endured freezing temperature (32 degrees or below).
- H22.10 Succulents, Cactus, spherical type.
- H22.11 Succulents, Cactus, columnar type.
- H22.12 Succulents, Cactus, epiphytic type.
- H22.13 Succulents, a collection of 3 or more plants in a single container.

H22.01-H22.08,

H22.10-H22.12 Point Scale:

Cultural Perfection55
Distinction15
Color Effect10
Form (according to variety)10
Rarity10

H22.09 Point Scale:

Cultural Perfection60
Distinction15
Form (according to variety)15
Rarity10

H22.13 Point Scale:

Cultural Perfection40
Distinction & Design25
Color Effect25
Grooming5
Suitable Labeling5

CLASS H24 TOPIARY CLASSES

Advisor: Sara Augustin 770-270-5256
 Trophies: Ballard, Herb Soc., Simmons, Smith, Species

Multiple entries made by same Exhibitor must be a different species or cultivar.

Underplanting and multiple genera accepted. Please state space required for exhibit on Entry Form. **Note: Hort. Rules 6d and 7c.**

H24.01	Topiary, single-stemmed standard, no frame.	H24 Point Scale:
H24.02	Topiary, stylized shape, other than standard, - single or multi-stemmed, no frame.	Cultural Perfection50
H24.03	Topiary, trained on a two- or three-dimensional frame, stuffed.	Distinction & Design20
H24.04	Topiary, trained on a two- or three-dimensional frame, unstuffed.	Maturity20
		Grooming10

2006 HORTICULTURE DIVISION CLASSES (Continued)

CLASS H28 BONSAI CLASSES

Advisors: Cozart Smith 404-373-3479
Shawn Williams 770-597-6107

Trophies: Herb Soc., Hodges, SFS, Smith, Species

*Bonsai will be judged during the first period only. Stands acceptable but not required. A natural tree form in miniature styled by the Exhibitor to be consistent with one of the following classifications below. Trees should be presented in a traditional bonsai container, in a stone or on a stone. **Tree must be in Exhibitor's possession at least 6 months.** Plant information should include the dimensions, style of tree and approximate age as well as the genus, species, and common name. Accent stones and small figurines are permitted. **Note: Hort. Rules 3 and 6d.**

H28.01	Bonsai, formal upright or broom.	H28 Point Scale:
H28.02	Bonsai, informal upright.	Cultural Perfection/
H28.03	Bonsai, mame (miniature).	Ramification40
H28.04	Bonsai, slant or windswept.	Form (according to style)
H28.05	Bonsai, cascade or semi-cascade.	Scale-Balance-Design25
H28.06	Bonsai, multiple trunk or forest.	Nebari-Rootage & Taper20
H28.07	Bonsai, stone planting.	Apparent Age, Maturity10
*H28.08	Bonsai, finished, not judged.	Preparation and Container
*H28.09	Bonsai, in transition, not judged.	Harmony5

CLASS H29 HERB CLASSES

Advisor: Tracy Minjauw 770-792-9263 . . .tracyminjauw@bellsouth.net

Trophies: Ballard, Herb Soc., Smith, Species

Note: Hort. Rules 6c, 6d and 7c.

H29.01	Herb, culinary.
H29.02	Herb, medicinal. State the historic medicinal use of herb on a separate 4" x 6" index card.
H29.03	Herb, fragrant.
H29.04	Herb, ornamental, decorative, or dye.
H29.05	Herb, collection of 3 or more, not in hanging container. Pots, troughs and strawberry jars are acceptable.
H29.06	Herb, collection, hanging container.

H29.01-H29.04 Point Scale:	H29.05-H29.06 Point Scale:
Cultural Perfection60	Cultural Perfection40
Condition & Grooming . .25	Distinction & Originality . . .30
Distinction10	Plant Compatibility20
Suitable Labeling5	Condition & Grooming5
	Suitable Labeling5

*Indicates important change

2006 HORTICULTURE DIVISION CLASSES (Continued)

CLASS H30 CARNIVOROUS PLANTS

Advisors: Brooks Garcia 404-624-1779atfinegardens@aol.com
 David Mellard 404-498-0443dmellard@cdc.gov
 Trophies: Ballard, SFS, Species

No wild collected plants allowed. Cultivars and man-made hybrids accepted with proper labels and parentage. Only propagated materials are allowed. Glass terrarium allowed, if necessary for humidity. **Note: Hort. Rules 6c, 6d and 7c.**

H30.01	Carnivorous, Venus Flytrap (<i>Dionaea muscipula</i>).	H30 Point Scale: Cultural Perfection60
H30.02	Carnivorous, Pitcher Plants (<i>Cephalotus</i> , <i>Darlingtonia</i> , <i>Heliophora</i> , <i>Nepenthes</i> , <i>Sarracenia</i>).	Condition & Grooming25 Distinction10 Suitable Labeling5
H30.03	Carnivorous, Sundews (<i>Byblis</i> , <i>Drosera</i> , <i>Drosophyllum</i>).	
H30.04	Carnivorous, Butterworts (<i>Pinguicula</i>).	
H30.05	Carnivorous, Bladderworts (<i>Utricularia</i>).	
H30.06	Carnivorous, collection of 3 or more.	
H30.07	Carnivorous, Miscellaneous (<i>Genlisea</i> , <i>Roridula</i> , <i>Catopsis</i> , <i>Brochinia</i>).	

CLASS H31 ULTIMATELY SMALL

Advisor: Martha Banks404-266-1477
 Trophies: Herb Soc., SFS, Species

Mature example of a species/cultivar that is one of the naturally diminutive members of the genus. Plant grown in 10" container or less. Natural underplanting is allowed. Man-made accessories are not permitted. A white 4" x 6" index card is required stating plant's approximate age and ultimate size. **Note: Hort Rules 6c and 7c.**

H31.01	Ultimately Small,** Conifers.	H31 Point Scale:
H31.02	Ultimately Small, Trees and Shrubs, other than Conifers.	Cultural Perfection50 Distinction & Originality30
H31.03	Ultimately Small, Herbaceous. (hardy and non-hardy).	Age15 Suitable Labeling5

**Conifers must conform to American Conifer Society standards of dwarf or miniature. (ACS website - conifersociety.org).

LANDSCAPE DIVISION

Co-Chairs	Andrea Huff770-521-1772pgazhuff@earthlink.net
	Ellen Ungashick ...404-255-8932ungy@earthlink.net
Committee	Theresa Schrum ...770-497-1011
	Eloise Boylan770-752-8682eloweze@aol.com
Advisors	Ginny Plummer ...404-237-4759 ...ginny.plummer@comcast.net
	Sandy Turbidy404-233-4878 ...sandmturbidy@earthlink.net

2006 LANDSCAPE DIVISION RULES

Theme: Inspiration, Education, Entertainment...

The Italian Experience

(Detailed information provided in Landscape Exhibitor's Handbook)

1. **All SFS General Rules except 1, 2, 3, 8, 9 and 10 apply.** (See pages 7-10.)
2. Landscape Division Awards are listed on pages 41 and 42.
3. Exhibitor must provide Statement of Purpose with plans for implementation.
4. Exhibit must remain in place throughout Show and must be maintained in Show condition.
5. To further public education, plant material in exhibit must be labeled with botanical and common names. Labels must be clear, waterproof, and unobtrusive.
6. No artificial plant material permitted in any part of the exhibit.

An Awards Ceremony will be held on Saturday, February 11, 2006, at 6:00 p.m.

7. **END OF SHOW REMOVAL:** The Show closes at 6:00 p.m. Sunday, February 12, 2006. No exhibit may be removed from Show Floor until 6:30 p.m.

2006 LANDSCAPE DIVISION CLASSES

Class L01	Large Garden	Over 900 Square Feet
Class L02	Medium Garden	500 - 900 Square Feet
Class L03	Small Garden	400 to 499 Square Feet
Class L04	Public Garden	Non-judged Class
Class L05	Pocket Garden	100 - 150 Square Feet
	(Pocket Garden Class is an introductory class limited to first-time Landscape Exhibitors)	

LANDSCAPE POINT SCALE FOR "BEST IN SHOW" AWARDS (L01, L02 & L03)

Design and Creativity40	Quality/Condition of Plants20
Effective Use of Plants30	Other10

For additional information, see Landscape Exhibitor's Handbook.

ACHIEVEMENT AWARDS (L01, L02 & L03) ARE JUDGED ON THE SPECIFIC CRITERIA DESCRIBED FOR EACH AWARD (see pages 41 and 42).

POCKET GARDEN CLASS (L05) IS JUDGED ON PAR**, USING THE LANDSCAPE POINT SCALE (see above).

** To be judged on Par means to be judged against perfection rather than against other exhibits.

PHOTOGRAPHY DIVISION

Co-Chairs	Jennifer Clements	770-333-8753
	Maria Mixson	404-355-7778
Committee	Suzi Modisett	404-355-6559
Advisor	Pat Hartrampf	404-231-2128

2006 PHOTOGRAPHY DIVISION RULES

1. **All SFS General Rules apply.** (See pages 7-10.)
2. **ELIGIBILITY:** Photographs entered in any previous Southeastern Flower Shows are not eligible. All Classes are open to ages 16 and older and to amateur and professional photographers alike. Current or previous SFS Photography Division judges are eligible to enter any Class, but their photographs will not be judged. Black and white and sepia-toned photographs may be entered in any Class. Manipulated images are permissible in any Class.
3. **ENTRIES:** Mailed entries may be submitted beginning October 1, 2005. You may use the 2006 Photography Division Entry Form found on page 51 of this Guide or in the Photography Division brochure which can be obtained by calling the Photography Division Co-Chairs or the SFS Office at 404-451-1074. You may download Entry Forms from the SFS website at www.flowershow.org. All entry forms and entry fees must be received by January 13, 2006.
 - No faxed or e-mailed entries will be accepted.
 - Exhibitor may enter a maximum of two Classes, one photograph per Class.
 - An entry fee of \$10.00 per photograph must accompany the Entry Form.
 - Mail check, payable to Southeastern Flower Show, and completed form to: Jennifer Clements, 3536 Paces Ferry Circle, Smyrna, GA 30080.
4. **REQUIREMENTS:**
 - All photographs must reflect the Mission Statement of the Southeastern Flower Show (see page 2) and are limited to subjects such as horticulture, gardens, landscapes, conservation, and subjects in our environment.
 - All photographs must be framed. White mats preferred.
 - All photographs must have a secure wire attached on the back for hanging. Photographs without wire attached will not be hung.
 - Framed photographs must not exceed 30" in either direction.
 - Photographs must be wrapped in bubble wrap for their protection.
 - Exhibitor's name, address, phone number, Class name, number, and title of each photograph must appear on the outside of the bubble wrap, as well as on the backside of the photo itself.
 - Unless mailed photographs are submitted with a self-addressed return box with adequate postage, we cannot be responsible for their return.
 - Plant identification encouraged when the image is specifically of a plant specimen. This information should appear on the back of the framed image.
5. **JUDGING:**
 - All classes will be judged once on Tuesday, February 7, 2006, at 10:00 a.m.
 - All photographs must remain for the duration of the Show, through 6:30 p.m., Sunday, February 12.
 - All rights remain with the photographer.
 - Awards will be placed alongside the photograph and may be taken home after the Show.

An Awards Ceremony for certificate winners will be held on Saturday, February 11, 2006, at 6:00 p.m.

2006 PHOTOGRAPHY DIVISION RULES (Continued)

- 6. ***SALE OF PHOTOGRAPHY:** Exhibitors wishing to sell their work may do so at the Show. Price your photograph to **INCLUDE SALES TAX OF 8%**. The required sales tax amount will be deducted from your stated price, as will a 20% (of the net after deducting sales tax) commission due SFS. For example: an item priced at \$108 will yield the seller \$80 (\$108 less \$8 sales tax less 20% commission). The photograph can be sold at any point during the Show through an SFS shop, but pickup will be limited to close of Show Sunday at GWCC or elsewhere if other arrangements have been made. Please indicate on the Entry Form if the artwork is for sale as well as the price. This information will be posted with the photograph during the Show. Photographs will be sold in their framed condition.

- 7. **DELIVERY OF PHOTOGRAPHS FOR EXHIBITION:** Deliveries accepted January 23 through February 1, 2006. Deliver to: Suzi Modisett, 631 Norfleet Road, NW, Atlanta, GA 30305 (Buckhead) 404-355-6559. Please call ahead to arrange delivery of your photographs. Directions: Norfleet Road is across the street from the Bitsy Grant Tennis Center on Northside Drive (Hwy 41). From I-75, exit Northside Drive. Take a left if you are coming from the north or a right if you are coming from the south (downtown Atlanta). Norfleet is between Collier Road and Peachtree Battle Avenue. #631 is the third house on the right from the corner of Northside Drive.

- 8. **REMOVAL:** All photographs must be picked up on Sunday, February 12 between 6:30 p.m. - 7:30 p.m. No exhibit may be removed from the Show until 6:30 p.m. Sunday, February 12. SFS cannot be responsible for work not picked up.

2006 PHOTOGRAPHY DIVISION CLASSES

Exhibitors in all Classes are eligible, if merited, for the SFS Certificate for Best in Show in Photography Division and SFS Certificate for Most Creative Image, unless otherwise noted. First, Second, and Honorable Mention ribbons in each Class may also be awarded.

- CLASS P02** BLACK AND WHITE OR SEPIA Be imaginative.
- CLASS P06** LANDSCAPES Show us out of the ordinary.
- CLASS P09** ALL ABOUT FLOWERS Any shape, any form - try something new!
- CLASS P10** UNUSUAL PLANT MATERIAL Try to stump the judges.
- CLASS P11** FAR OFF PLACES - TRAVEL Carry us away from February in Atlanta.
- CLASS P12** *WATER In any of its forms.
- CLASS P13** *PEOPLE AND OTHER CRITTERS Capture life of all sorts.

2006 PHOTOGRAPHY DIVISION POINT SCALE

Composition30	Technical Merit30
Creativity and Distinction30	Interpretation of Class Theme10

*Indicates important change.

PROFESSIONAL DESIGN DIVISION

Co-ChairsElizabeth Martin 404-351-8208elizmartin@aol.com
Stella Martin 404-351-0938stellaiii@comcast.net
AdvisorRobert Long 404-365-0500

2006 PROFESSIONAL DESIGN DIVISION RULES

1. **All SFS General Rules apply.** Detailed Class Rules and specifications will be provided with entry acknowledgment.
2. **ENTRIES:** Mailed or faxed entries may be submitted beginning September 15, 2005. You may use the 2006 Professional Design Division Entry Form found on page 53 of this Guide or you may download Entry Forms from the SFS website at www.flowershow.org. All entries must be received by January 16, 2006. Exhibitors who enter the Professional Design Division are not eligible to enter the Artistic Floral Design Division or the Garden Design Division in 2006 or in 2007.
3. **ELIGIBILITY:** Open to professional floral designers **by invitation only**.
4. **JUDGING:** Classes PD01 and PD02 will be judged each judging period for the Adelle Bartlett Harper Trophy and the SFS Maintenance Certificates only. (PD01 and PD02 are not eligible for other awards or ribbons.)

An Awards Ceremony for trophy winners will be held on Saturday, February 11, 2006 at 6:00 p.m.

5. REQUIREMENTS:

- Fresh plant material must predominate; no potted and no dried material are permitted.
- Exhibitor must keep arrangement(s) fresh and in Show condition at all times. Unightly or wilted plant material must be replaced. Grooming/watering must be completed by 9:00 a.m. daily.
- Mechanics must not show unless they are an intrinsic part of the design.
- Container and/or props are the designer's choice.
- A Plant List with common and botanical names is required.

6. **TITLE, STATEMENT OF PURPOSE AND PLANT LIST:** A title, theme interpretation (Statement of Purpose), and Plant List must accompany each exhibit. Use black waterproof ink, and legibly print or type all forms. Put your title and theme interpretation on a 4" x 6" index card or use the form on page 55 (Statement of Purpose). A Plant List with the correct botanical and common name of all plant material must also accompany each exhibit. You may use the form on page 57 (Plant List) of this Guide, or you may make a Plant List on an 8.5" x 11" plain white piece of paper.

7. **INSTALLATION:** Entries may be installed during the following times:

First Installation:	Monday	February 6	4:00 p.m. - 8:00 p.m.
Second Installation:	Thursday	February 9	7:00 p.m. - 8:30 p.m.

8. **END OF SHOW REMOVAL:** The Show closes at 6:00 p.m. Sunday, February 12, 2006. No exhibits may be removed from the Show Floor until 6:30 p.m.

2006 PROFESSIONAL DESIGN DIVISION CLASSES

Theme: Inspiration, Education, Entertainment...

The Italian Experience

CLASS PD01 Antonio Vivaldi's 'The Four Seasons'

Interpretive Design

Interpret one of 'The Four Seasons' in a mass floral design.

- Staged on a dark green pedestal provided by SFS, 20" x 20" square, 43" high. Design must be a minimum of 35" high including container.
- Floral design to consist of all fresh plant material.
- Contact Division Chair to claim your "season."
- Limited to four entries per judging period.

CLASS PD02 La Dolce Vita

Interpretive Design

Forget Domani and interpret La Dolce Vita in a floral design.

- Exhibit allotted a 4' x 4' square design space to include all components (pedestal, arrangement, props). Overall design height is unrestricted. Pedestals will be available if desired or you may provide your own pedestal. Contact Division Chair to determine pedestal choice or other staging.
- Floral design to consist of all fresh plant material.
- Limited to four entries per judging period.

* Indicates new Class or important change

YOUTH DIVISION

ChairDian Deimler 404-874-3744 ddeimler@bellsouth.net
Entry ChairLinda Caminiti 770-552-9477leisure50@comcast.net
AdvisorsCary Lide 404-356-3878lidec@bellsouth.net
Anne Wilson 404-231-7944 annepwilson@mindspring.com

2006 YOUTH DIVISION RULES

Theme: Passport to Italy

The complete Youth Division Exhibitor's Guide, rules for entry and Entry Forms can be found online at www.flowershow.org or can be requested from the SFS Office by calling 404-351-1074.

- 1. ELIGIBILITY:** Individuals or groups designated as Youth (first grade through high school)
Youth Grade categories:
 - a) - Grades 1 - 5;
 - b) - Grades 6 - 8;
 - c) - Grades 9 - 12
- 2. ENTRY:**
 - Entries will be accepted in the order received.
 - Class size is limited.
 - Deadline for entry is January 19, 2006.
 - All entries remain for both judging periods with exception of Flower Arranging (Class Y03).
- 3. See page 42 for a list of Youth Division Awards.**

An Awards Ceremony for trophy and certificate winners in the Youth Division will be held on Sunday, February 12 at 5:00 p.m. in the Studio area on the Show Floor.

- 4. END OF SHOW REMOVAL:** The Show closes at 6:00 p.m. Sunday, February 12, 2006. No exhibit may be removed from the Show Floor until 6:30 p.m. Please make arrangements to pick up your Exhibit between 6:30 and 7:30 p.m. on Sunday, February 12. SFS cannot be responsible for items remaining on the Show Floor.

2006 YOUTH DIVISION CLASSES

- CLASS Y01:** Bountiful Buffet - Edible Salad Plants
CLASS Y02: Il Giardino Sacro - Mediterranean Plants of Italy
CLASS Y03: Design Challenge - Risen From Ashes - Pompeii (Flower Arranging)
CLASS Y04: Italy: The Boot Sprouts - Sprout a Seed
CLASS Y05: Art in the Garden - Harlequins
***CLASS Y06:** Photography

TROUGH GARDEN CLASS

During this two-day class you will make your own trough for a trough garden. All materials for the trough will be provided with the fee. Appropriate plants for your trough garden and their continuing care will be discussed during the class.

First Day: Saturday, October 1 9:30 - 11:00 a.m. - Grades 1-5 12:00 - 1:30 p.m. - Grades 6-12	Second Day: Sunday, October 2 1:00 - 2:30 p.m. - All Grades
Location: Southeastern Flower Show Offices 1705 Commerce Drive N.W. Suite 400 Atlanta, GA 30318	Instructor: Virginia Almand Fee: \$25

For additional information and to register for the class, call Dian Deimler, Youth Division Chair, at 404-874-3744.

*Indicates new Class or important change

2006 SOUTHEASTERN FLOWER SHOW AWARDS

Unless designated otherwise, the trophies have been donated to the SFS and remain on permanent display at the Atlanta Botanical Garden. All recipients of the SFS display trophies are given a framable certificate and a presentation photo of the trophy.

The first Show year that the award was presented is shown in parenthesis after the name of the award.

An award may not be given if required Classes are not offered or if judges feel award is not merited. Specific trophy eligibility information is available to Exhibitors from Division Chairs or Class Advisors.

An Awards Ceremony for trophy winners will be held on Saturday, February 11 at 6:00 p.m.

ARTISTIC FLORAL DESIGN DIVISION AWARDS

Awarded, if merited, each judging period unless otherwise noted. An SFS certificate and framable photo of the display trophy (where applicable) given to each recipient.

Becky Chiles Cox Trophy (1988) - for best table. A covered silver trophy cup donated by her great-niece, Vernona McDuffie Tambke.

Corinne Clarke Reynolds Trophy (1990) - for best tableau. A "tableau" is a scene or setting; e.g., a vignette, mantel, or plateau. A covered silver trophy cup donated by her daughter, June Reynolds MacKaye, and granddaughters, June Reynolds Davis, Dottie Corinne Houser and Christienne Bailey MacKaye.

James Crawford Foreman Trophy (1990) - for most creative niche interpreting the Class theme. A three-handled silver trophy cup donated in his memory.

Louise Brown Hastings Trophy (1990) - for best mass arrangement using only fresh plant material. An octagonal silver vase donated in her memory by her family and the Habersham Garden Club.

Lucile Goodwin Davison Trophy (1988) - for best indoor setting. A silver loving cup donated by her daughter, Margaret Davison Block.

Magnolia Garden Club Trophy (1990) - for best overall outdoor setting. A silver trumpet vase.

Mary Reynolds Morrison Trophy (1990) - for most outstanding floral arrangement in a niche. A chased silver strawberry basket donated by her family.

Peachtree Garden Club Trophy (1988) - for best artistic arrangement using only fresh cut plant material. The Tri-color Award for Artistic Excellence: limited to Blue Ribbon winners. A large, oval silver tray. A red/yellow/blue rosette given to recipient.

Piedmont Garden Club Trophy (2000) - for best novice entry by an individual in Garden Design or Artistic Floral Design Divisions. A round silver tray with reticulated border.

Pine Tree Garden Club Trophy (1988) - for most creative arrangement using fresh and/or dried plant material. The Purple Creativity Award for creative excellence; limited to Blue Ribbon winners. An oblong silver tea service tray. A purple rosette given to recipient.

Rebecca Wight Cherry Sims Trophy (1990) - for best Asian design in any Class. A silver Victorian teakettle donated in her memory by the Garden Center of Greater Atlanta.

SFS Maintenance Certificates (1998) - for best maintained exhibit in its Class during a judging period.

DISCOVERY DIVISION AWARDS

Awarded, if merited, first judging period only. An SFS certificate and framed photo of the display trophy (where applicable) given to each recipient.

American Horticultural Society Environmental Award (1989) - for an exhibit of horticultural excellence that best demonstrates the bond between horticulture and the environment, and inspires the viewer to beautify the home and community through skillful design and appropriate plant material. A crystal trophy from the Society given to recipient.

DISCOVERY DIVISION AWARDS (Continued)

Ardmore Publishing Company “Garden in Literature” Trophy (1999) - for an exhibit demonstrating the interrelation of the garden and literature. A silver basket.

Atlanta Botanical Garden “Blue Ribbon Certificate of Excellence” (1992) - for participation by students in designing and creating an educational exhibit. A special certificate given to recipient.

Atlanta Botanical Garden Certificate (1992) - for an educational exhibit demonstrating sound conservation practices. A special certificate given to recipient.

Boxwood Garden Club Trophy (1998) - for the educational garden with most year-round interest emphasizing the use of native Southeastern plants. An etched crystal flower basket.

Caroline Paullin Minnich Trophy (1999) - for the garden that best creates an atmosphere of learning through discovery. A round silver tray, honoring Caroline Paullin Minnich, donated by her children: Cary Lide, Gail Watson, and Bill Minnich.

Chicago Horticultural Society Flower Show Medal (1989) - for the exhibit showing outstanding horticultural skill and knowledge. A medal from the Society given to recipient.

Governor’s Trophy (1988) - for the educational exhibit of greatest distinction. A silver trumpet vase donated by Callie Huger Efird. A maroon/light green rosette given to recipient.

Horticultural Society of New York Award, The (1990) - for best use of plants in an urban environment. A special certificate from the Society given to recipient.

Lady Bird Johnson Award (1992) - for the exhibit that best increases the knowledge of naturalizing, preserving and beautifying outdoor areas. A special certificate given to recipient.

Magnolia Garden Club Scholarship Trophy (1997) - for an exhibit created by an academic institution or nonprofit organization that best exemplifies excellence in environmental education. A silver bowl. A cash award given to recipient.

Pike Family Nurseries “Play in the Dirt” Trophy (1999) - for the garden that most successfully captures the spirit of family and fun. An etched green glass trophy with silver cover.

SFS Trophy of Merit (1995) - for a garden of special merit. A silver compote.

SFS Plant Discoveries Awards (2005) - for an exhibit that spotlights related plants of horticultural merit, adding to the public knowledge of these plants, their use in the garden and their beauty. The Plant Discoveries exhibits are judged on Par (judged against perfection rather than against other exhibits), using an established Point Scale (see page 16). Gold, Silver, and Bronze Certificates awarded to recipients.

GARDEN DESIGN DIVISION AWARDS

Awarded, if merited, each judging period unless otherwise noted. An SFS certificate and framable photo of the display trophy (where applicable) given to each recipient.

Edith Henderson Trophy (1995) - for the exhibit that best demonstrates good design and innovative use of plant material. An etched silver cake basket, in honor of a leader in landscape design, donated by fellow Peachtree Garden Club members.

Ivy Garden Club Trophy (1995) - for best exhibit in the Pot et Fleur Class. A Victorian silver flower basket.

Mary Wylie McCarty Trophy (1988) - for best exhibit in Garden Design. A Victorian silver chalice donated by Eleanor Atuk, Augusta Horsey, Sarah McAlpin, and Eleanor Ridley. A hunter green/gold rosette given to recipient.

Piedmont Garden Club Trophy (2000) - for best novice entry by an individual in Garden Design or Artistic Floral Design Divisions. A round silver tray with reticulated border.

SFS Maintenance Certificates (1998) - for the best maintained exhibit in its Class during a judging period.

Sue Marshall Smith Trophy (1991) - for most distinctive exhibit in Horticulture or Garden Design where herbs are included. A silver medallion on a wood plaque donated by GardenSmith Greenhouse.

HORTICULTURE DIVISION AWARDS

Awarded, if merited, each judging period, unless otherwise noted. An SFS certificate and framable photo of the display trophy (where applicable) given to each recipient.

Ann Equen Ballard Trophy (2001) - for an outstanding collection of three or more species or cultivars. A silver Revere bowl donated in her memory by her family and friends.

Candy Jones Simmons Trophy (2005) - for most outstanding topiary. An Art Deco silver bud vase given in her honor by fellow Mimosa Garden Club members.

Cherokee Garden Club Trophy (1988) - for the individual with the most points in Horticulture. An oblong silver tea service tray.

Cornelia Heffernan Lyon Trophy (1988) - for "single best unusual Fern exhibit." A reticulated silver trumpet vase donated by her daughter, Ann Lyon Crammond.

Dorothy Dean Harris Trophy (1989) - for best exhibit in Begonia Class. A fluted silver bowl donated by Mr. & Mrs. Haines Hargrett, Jr.

Edna Frederick Paullin Trophy (1989) - for best exhibit in Camellia Class. A shell-shaped silver dish donated by her family.

Erma Tippins Hodges Trophy (1992) - for best outdoor grown Camellia exhibit. A silver bonbon bowl donated in her mother's memory by Eileen Hodges Small.

***Gena Moran Trophy** (2002) - for the finest Ivy exhibit demonstrating horticultural excellence. Awarded after the second judging period. A crystal plaque given to recipient by the Atlanta Chapter of the American Ivy Society in honor of their founder.

Habersham Garden Club Presidents Trophy (2001) - for best exhibit in Bulb Class. A silver bowl honoring all Habersham Garden Club Presidents.

Herb Society of America, Chattahoochee Unit Trophy (1990) - for best single herb exhibit in a non-professional Class. A silver tussie-mussie holder.

Jitsuko Yamanashi Johnson Trophy (2002) - for most outstanding exhibit in Cut Specimen Classes. A boron glass sculpture of a cherry blossom branch donated in her memory by her friends.

Johne Dodgen Swanson Trophy (1988) - for best exhibit in Par Class. A silver trumpet vase donated in his mother's memory by George E. Swanson, Jr.

Mary Thiesen Morrison Award (1988) - for best artistically planted miniature landscape with compatible plants of horticultural excellence. A miniature silver tea service donated by her family.

Max Ellenberg Orchid Trophy (1994) - for best specimen Orchid plant in the Classes of Orchids, Plants of the World, or Pro's Corner. Professional growers eligible; awarded first judging period only. A crystal plaque, etched with an orchid, donated in his honor by Dr. & Mrs. William A. Ellenberg.

Northwood Garden Club Trophy (1988) - The Horticulture Excellence Award for Best in Show. Limited to Blue Ribbon winners in any non-professional class. A silver wine cooler with liner. A kelly green/white rosette given to recipient.

SFS Awards of Excellence (1999) - for most outstanding exhibit in each Class where no specific Class trophy is given. Limited to Blue Ribbon winners. A small sapphire/raspberry rosette is given to recipients.

Species Trophy (2001) - for most outstanding species** in the Horticulture Division. Awarded after the first judging period. A crystal plaque (designed and donated by Larry and Linda Mayse) given to recipient.

Sue Marshall Smith Trophy (1991) - for most distinctive exhibit in Horticulture or Garden Design where herbs are included. A silver medallion on a wood plaque donated by GardenSmith Greenhouse.

* Indicates new trophy or important change to trophy criteria.

** Species: Closely related similar individual plants that occur naturally in the wild and have not had human intervention.

LANDSCAPE DIVISION AWARDS

Awarded, if merited, first judging period only. An SFS certificate and framed photo of the display trophy (where applicable) given to each recipient.

I. Best in Show Awards (L01, L02 & L03 - based on Landscape Point Scale [see page 32]):

Atlanta Botanical Garden Trustees' Trophy for Best in Show (1994) - for an exceptional exhibit that exemplifies the goals of the Southeastern Flower Show. A silver Franklinia branch in a crystal vase. A crystal plaque (designed and donated by Larry Mayse of Nature Glassworks) and special green/blue/yellow rosettes given to the recipient in each of the three above Landscape Classes.

II. Achievement Awards (L01, L02 & L03 - Judged on the specific criteria described for each award):

American Society of Landscape Architects Trophy (1989) - for best use of annuals and/or perennials as a design element. A silver wine cooler donated by the Georgia Chapter.

Ann Lyon Crammond Trophy (1989) - for "the garden that invites you in." A silver chalice donated in her honor by the Atlanta Botanical Garden.

Charlotte Robertson Edwards Trophy (1991) - for the garden that maximizes a shady area. A silver sandwich tray donated by her family.

Coastal Pond/Fountain Company Trophy (1999) - for best use of a water feature. A crystal trophy, provided by Bill Dowden, given to recipient.

Dargan Landscape Architects Trophy (1998) - for the small landscape that most successfully inspires the home gardener. An antique Pratt Ware sugar bowl.

Fine Gardening Magazine Trophy (1992) - for most accomplished display of forced plants. A pewter Revere bowl.

Gardens for Peace Trophy (2005) - for the garden that best represents the design principles of harmony, balance, and unity. Honoring the 20th anniversary of the founding of Gardens for Peace by Dr. Laura Dorsey and her mother Laura Whitner Dorsey. An engraved crystal plaque.

Georgia Commercial Flower Growers Association Trophy (1989) - for exceptional use of color in a garden or exhibit. A footed silver centerpiece bowl.

Georgia Lighting Company Trophy (1991) - for most distinctive and creative use of hardscapes in a garden. A silver centennial cup.

Grace L. Hightower Trophy (1992) - for most distinguished woodland garden. A covered silver trophy cup donated by her granddaughter, Laura P. Hagler.

Iris Garden Club Trophy (2005) - for best use of shrubs and trees to create structure in a garden. A silver obelisk.

Louyse Berry Turbidity Trophy (1991) - for best first-year garden of any size. A silver compote donated by her family.

Lynn Dowden Trophy (2002) - for best use of water in a garden setting. A crystal trophy, provided by Bill Dowden in his wife's honor, given to recipient.

Mabel Gunter Massie Trophy (1992) - for an exceptional garden designed primarily for sun. An oval repoussé silver tray donated by her daughter, Cynthia Massie Turoff.

Massachusetts Horticultural Society Medal (1989) - for best execution of design. A medal from the Society given to recipient.

***Men's Garden Club of Atlanta Trophy** (1989) - for best use of plants native to the Piedmont area. A round silver plate.

Metro Atlanta Landscape and Turf Association Trophy (1989) - for best form and quality of plant materials. A silver wine cooler.

Peach 94.9 FM WPCB Trophy (1989) - for most traditional Southern garden. A crystal iris sculpture.

Pennsylvania Horticultural Society Award (1989) - for an exhibit featuring the best use of distinguished horticultural material in a garden setting. A special certificate from the Society given to recipient.

Planters Garden Club Trophy (1991) - for most creative interpretation of the theme. A silver trophy cup.

Robinson Whimsical Trophy (1992) - for a garden that exhibits humor, fantasy and/or whimsy, and displays horticultural skill and beauty. An "Objet du Jardin" donated by Olive Robinson.

*Indicates a new trophy or important change.

LANDSCAPE DIVISION AWARDS (Continued)

SFS Trophy of Merit (1994) - for a garden of special merit. A silver Revere bowl.

***Southern Living-Southern Accents Trophy** (1989) - for best designed Southern garden. A brass clock in a wood case.

William L. Pike Trophy (2005) - for the garden that captures the essence of a southeastern backyard landscape, integrating a harmonious blend of living and garden spaces and utilizing good horticultural and design principles. A silver leaf-shaped tray donated in his honor by his family.

III. The People's Choice Award (L01, L02 & L03):

Mayor's Trophy (1988) - for the people's favorite landscape garden. By ballot vote of attendees on the first four days of the Show (Opening Night Party, Wednesday, Thursday and Friday). A Wedgwood bowl donated by Ivan Allen, Jr., the late mayor emeritus of Atlanta.

IV. The Maintenance Awards (L01, L02 & L03):

James E. Hinkle Award (1994) - for the landscape garden in each Class best maintained throughout Show. Cash award given to recipient in each Class.

IV. Pocket Garden Awards (L05):

SFS Pocket Garden Awards (2005) - for the 100-150 square foot garden, limited to first-time Landscape Exhibitors. Judged against perfection rather than against other exhibits, using an established Point Scale (see page 32). Gold, Silver, and Bronze Certificates awarded to recipients.

PHOTOGRAPHY DIVISION AWARDS

Awarded, if merited, first judging period only.

SFS Certificate for Best in Show in Photography Division - for the exhibit that successfully combines superlative composition, technical excellence and a creative approach to produce the best photograph in the Show. An SFS certificate and a black/white rosette given to recipient.

SFS Certificate for Most Creative Image - for an outstanding exhibit that best displays the imaginative skill of the photographer in creating a new and unusual image. An SFS certificate and a white/black rosette given to recipient.

PROFESSIONAL DESIGN DIVISION AWARDS

Awarded, if merited, each judging period, unless otherwise noted.

Adelle Bartlett Harper Trophy (1990) - for best arrangement in Professional Design Division. A covered silver tureen won by Mrs. Harper, a professional flower arranger, as Atlanta Woman of the Year for Business in 1951, and donated by her family in her memory. An SFS certificate, framed photo of the display trophy, and a purple/sapphire rosette given to recipient.

SFS Maintenance Certificates (1998) - for best maintained exhibit in its Class during a judging period.

YOUTH DIVISION AWARDS

Awarded, if merited, first judging period only, unless otherwise noted. An SFS certificate and framable photo of the display trophy (where applicable) given to each recipient.

First Lady of Georgia Award (2002) - for best exhibit in the Youth Division. First presented by former First Lady of Georgia, Marie Barnes, a special certificate along with a blue rosette given to recipient.

Fred Bley Trophy (1997) - for most creative expression in the Youth Division. A finely turned Acer 'Red Leopard' wooden bowl donated by friends of "Mr. Fred." A blue rosette given to recipient.

Margaret Davison Block Trophy (1997) - for best flower arrangement in the Youth Division. Awarded each judging period. Margaret's silver baby cup donated by her family and friends. A blue rosette given to recipient.

Sarah Orme Huger Trophy (1988) - for best horticultural entry in the Youth Division. A silver posy basket honoring "Big Sarah." A blue rosette given to recipient.

* Indicates important change to trophy criteria.

SPECIAL PANEL AWARDS

Awarded, if merited, for entire Show.

Bulkley Medal (1990) - Garden Club of America - for a special exhibit in the fields of horticulture, botany, or conservation. The exhibit must be one of exceptional educational merit that increases the knowledge and awareness of the viewing public. May be awarded to Garden Club of America (GCA) members, member clubs, non-members, or other organizations at a major flower show sponsored by a nationally recognized horticultural organization. The medal from GCA given to recipient.

Certificate of Excellence in Flower Arranging (1990) - Garden Club of America - for an exhibit of great distinction in a competitive Flower Arrangement Class of a major flower show. May be awarded to GCA members or clubs, other clubs, organizations, societies or individuals. The entry must have placed First, Second, or Third. A special certificate from GCA given to recipient.

Certificate of Excellence in Horticulture (1990) - Garden Club of America - for an exhibit of great distinction in a competitive Class in the Horticulture Division of a major flower show. May be awarded to GCA members or clubs, other clubs, organizations, societies or individuals. The entry must have placed First, Second, or Third. A special certificate from GCA given to recipient.

Certificate of Excellence in Conservation (1997) - Garden Club of America - for an exhibit of exceptional merit that educates the public on conservation issues and promotes respect for natural resources and responsibility for environmental stewardship. A special certificate from GCA given to recipient.

National Garden Clubs Medals (1998) - for the exhibits in both Artistic Floral Design and Horticulture Divisions judged by an NGC panel to be the finest, a Blue Ribbon winner scoring 95 points or more, in a major non-Standard Flower Show. A framed medal from the NGC, depicting the NGC, Inc. seal, given to each recipient.

SWEEPSTAKES AWARDS

Awarded, if merited, for entire Show. (Refer to General Rule 8 for details.)

A framable photo of the display trophy and special certificate given to each recipient.

Ann Oliver Newton Cobb Sweepstakes Trophy (1994) - for the individual living outside the Atlanta metro area with most combined points in Horticulture (at least 8) and at least 8 points in Artistic Floral Design and/or Garden Design.** A silver trumpet vase donated in her memory as the first president of America's first garden club by her great-granddaughter, Mrs. Franklin L. Burke.

Eleanor Stout McRae Artistic Sweepstakes Trophy (1988) - for the individual with most points (at least 10) in Artistic Floral Design for the entire Show. A silver loving cup donated by Floyd Wilcox McRae, Jr. and Margaret Clark McRae.

Lynda Lowe Willingham Sweepstakes Trophy (1990) - for the individual with most combined points in Horticulture (at least 8) and at least 8 points in Artistic Floral Design and/or Garden Design. A two-handled silver wine cooler donated by her children, Sally Willingham Hawkins and Thomas Marion Willingham, II.

Margaret Sheffield Martin Sweepstakes Trophy (1997) - for garden club outside Atlanta metro area ** with most combined points in Horticulture (at least 8) and at least 8 points in Artistic Floral Design and/or Garden Design. An antique porcelain dish donated by her children in recognition of her vision and steadfast support of the SFS.

Marion Peel Calhoun Horticulture Sweepstakes Trophy (1988) - for the individual with most points (at least 10) in Horticulture. A three-handled silver trophy cup donated in honor of Mrs. Calhoun, Chairman of the first Atlanta Flower Show in 1937, by her granddaughter, Dollie Cardwell Swanson.

SFS Sweepstakes Trophy (1988) - for the large garden club whose members accumulate most combined points in Horticulture (at least 8) and at least 8 points in Artistic Floral Design and/or Garden Design. Open to garden clubs with over 60 active members. A covered silver trophy cup donated in 1932 by Mrs. James D. Robinson, a member of Peachtree Garden Club, and rededicated in 1988.

SFS Trophy of Achievement (1992) - for the smaller garden club whose members accumulate most combined points in Horticulture (at least 8) and at least 8 points in Artistic Floral Design and/or Garden Design. Open to garden clubs with a maximum of 60 active members. A silver trumpet vase.

**Comprised of Clayton, Cobb, DeKalb, Fulton and Gwinnett Counties.

VOLUNTEER SERVICE AWARDS

Day Company Trophy (1988) - for the garden club with the most volunteer hours for the Show. The hours spent on individual or group competitive exhibits are not included. Each SFS Committee member is credited with a maximum of 35 hours towards this award. SFS Committee Chairs and/or Co-Chairs are credited with 50 hours each. A fluted silver Revere bowl. A trophy photo and special certificate given to recipient.

Patricia Crawford Hartrampf Trophy (1990) - for the volunteer whose leadership has made the most significant contribution to the Show. A silver trumpet vase donated by her family in honor of her service as the first Flower Show Chairman. A silver pendant, trophy photo and special certificate given to each year's recipient.

Robert McGee Balentine Horticulture Trophy (1996) - for an individual or group in the Southeastern United States who has made a significant contribution to the field of horticulture. In memory of this SFS trustee and supporter, a Hans Frabel crystal trophy and special certificate given to each year's recipient.

SFS Corporate Award of Excellence (2001) - for that corporation that has consistently contributed in a substantial manner to the growing success of the Southeastern Flower Show. Awarded by the Board of Trustees when deemed appropriate. A presentation piece and special certificate given to recipient.

SFS Ryan Gainey Trophy (1998) - for an individual in recognition of consistently outstanding support of the Show over a period of years through his or her field of professional endeavor. Awarded by the SFS Board of Trustees when deemed appropriate. A Hans Fräbel crystal acorn sculpture and special certificate given to each year's recipient.

POINT COUNT FOR RIBBONS AND AWARDS

RIBBONS:	Points
Blue	10
Red	8
Yellow	6
White	3

TROPHIES:	
Special Panel Awards	30
Cherokee, McCarty, Northwood, Peachtree, Pine Tree	25
SFS Awards of Excellence	15
All other Artistic Floral Design, Garden Design, and Horticulture Awards	20
SFS Maintenance Awards	2*

SWEEPSTAKES:	
Calhoun, McRae	30
Cobb, Willingham	35

* Indicates important change.

2006 ARTISTIC FLORAL DESIGN DIVISION INDIVIDUAL ENTRY FORM

Your early entries are greatly appreciated. Please type or print clearly in black ink.
See General Rules 1, 2, and 3 prior to completing the form.

This form is for Individual Entries. Please go to page 46 for the Group Entry Form.
Refer to General Rule #2 (page 7) for definition of Individual Entry and Group Entry.

MAIL TO: CATHY PHELAN
1399 Peachtree Battle Ave., N.W.
Atlanta, GA 30327

DEADLINE: JANUARY 16, 2006
PHONE: 404-352-3492

EXHIBITOR:

First Name	Middle	Last	Phone ()
Address			Fax ()
City	State	Zip	County
E-mail address:		Principal residence inside Atlanta metro area?*** YES () NO ()	
If member of Garden Club*, (a) Full name of Garden Club _____			
(b) Primary County _____ Garden Club of GA District _____			
(c) Does the majority of its membership reside inside the Atlanta metro area?*** YES () NO ()			
(d) Is your garden club limited to a maximum of 60 active members? YES () NO ()			
First-time Exhibitor in the Show? YES () NO ()			
CO-EXHIBITOR (IF ANY):			
First Name	Middle	Last	Phone ()
Address			Fax ()
City	State	Zip	County
E-mail address:		Principal residence inside Atlanta metro area?*** YES () NO ()	
If member of Garden Club*, (a) Full name of Garden Club _____			
(b) Primary County _____ Garden Club of GA District _____			
(c) Does the majority of its membership reside inside the Atlanta metro area?*** YES () NO ()			
(d) Is your garden club limited to a maximum of 60 active members? YES () NO ()			
First-time Exhibitor in the Show? YES () NO ()			
NOVICE? YES () NO () Refer to General Rule #3a (page 7) NOTE: Applies to BOTH Co-Exhibitors.			

EXHIBIT INFORMATION

Class Number	ARTISTIC FLORAL DESIGN DIVISION CLASSES Exhibit Title	Please ✓ Judging Period	
		1st	2nd
Example:	(List title if known.)		
A01 Small Niche	TBD	✓	✓

* Must be answered to qualify for certain Sweepstakes Awards.

** Metro Atlanta is comprised of Clayton, Cobb, DeKalb, Fulton and Gwinnett Counties.

2006 ARTISTIC FLORAL DESIGN DIVISION GROUP ENTRY FORM

Your early entries are greatly appreciated. Please type or print clearly in black ink.
See General Rules 1, 2, and 3 prior to completing the form.

This form is for Group Entries. Please go to page 45 for the Individual Entry Form.
Refer to General Rule #2 (page 7) for definition of Individual Entry and Group Entry.

MAIL TO: CATHY PHELAN
1399 Peachtree Battle Ave., N.W.
Atlanta, GA 30327

DEADLINE: JANUARY 16, 2006
PHONE: 404-352-3492

EXHIBITOR:

Name of Group _____	
If Garden Club*: _____	
(a) Primary County _____	Garden Club of GA District _____
(c) Does the majority of its membership reside inside the Atlanta metro area? ** YES () NO ()	
(c) Is your garden club limited to a maximum of 60 active members? YES () NO ()	

CONTACTS:

First Name	Middle	Last	Phone ()
Address		Fax ()	
City	State	Zip	County
E-mail address:			
First Name	Middle	Last	Phone ()
Address		Fax ()	
City	State	Zip	County
E-mail address:			

EXHIBIT INFORMATION

Class Number	ARTISTIC FLORAL DESIGN DIVISION CLASSES Exhibit Title	Please ✓ Judging Period	
		1st	2nd
Example:	(List title if known.)	1st	2nd
A16 Vignette	TBD	✓	✓

* Must be answered to qualify for certain Sweepstakes Awards.

** Metro Atlanta is comprised of Clayton, Cobb, DeKalb, Fulton and Gwinnett Counties.

2006 GARDEN DESIGN DIVISION INDIVIDUAL ENTRY FORM

Your early entries are greatly appreciated. Please type or print clearly in black ink.
See General Rules 1, 2, and 3 prior to completing the form.

This form is for Individual Entries. Please go to page 48 for the Group Entry Form.
Refer to General Rule #2 (page 7) for definition of Individual Entry and Group Entry.

MAIL TO: AMY H. WOOD
2180 Howell Mill Road
Atlanta, GA 30318

DEADLINE: JANUARY 19, 2006
PHONE: 404-352-1385
E-MAIL: amy.wood@alexanderkey.com

EXHIBITOR:

First Name	Middle	Last	Phone ()
Address			Fax ()
City	State	Zip	County
E-mail address:		Principal residence inside Atlanta metro area? ** YES () NO ()	
If member of Garden Club*, (a) Full name of Garden Club _____			
(b) Primary County _____ Garden Club of GA District _____			
(c) Does the majority of its membership reside inside the Atlanta metro area? ** YES () NO ()			
(d) Is your garden club limited to a maximum of 60 active members? YES () NO ()			
First-time Exhibitor in the Show? YES () NO ()			
CO-EXHIBITOR (IF ANY):			
First Name	Middle	Last	Phone ()
Address			Fax ()
City	State	Zip	County
E-mail address:		Principal residence inside Atlanta metro area? ** YES () NO ()	
If member of Garden Club*, (a) Full name of Garden Club _____			
(b) Primary County _____ Garden Club of GA District _____			
(c) Does the majority of its membership reside inside the Atlanta metro area? ** YES () NO ()			
(d) Is your garden club limited to a maximum of 60 active members? YES () NO ()			
First-time Exhibitor in the Show? YES () NO ()			
NOVICE? YES () NO () Refer to General Rule #3a (page 7) <i>NOTE: Applies to BOTH Co-Exhibitors.</i>			

EXHIBIT INFORMATION

Class Number	GARDEN DESIGN DIVISION CLASSES Exhibit Title	Please ✓ Judging Period	
		1st	2nd
Example:	(List title if known.)	1st	2nd
G04 Pot et Fleur	TBD	✓	✓

* Must be answered to qualify for certain Sweepstakes Awards.

** Metro Atlanta is comprised of Clayton, Cobb, DeKalb, Fulton and Gwinnett Counties.

2006 GARDEN DESIGN DIVISION GROUP ENTRY FORM

Your early entries are greatly appreciated. Please type or print clearly in black ink.
See General Rules 1, 2, and 3 prior to completing the form.

This form is for Group Entries. Please go to page 47 for the Individual Entry Form.
Refer to General Rule #2 (page 7) for definition of Individual Entry and Group Entry.

MAIL TO: AMY H. WOOD
2180 Howell Mill Road
Atlanta, GA 30318

DEADLINE: JANUARY 19, 2006
E-MAIL: amy.wood@alexanderkey.com

EXHIBITOR:

Name of Group _____			
If Garden Club*:			
(a) Primary County _____		Garden Club of GA District _____	
(c) Does the majority of its membership reside inside the Atlanta metro area? ** YES () NO ()			
(c) Is your garden club limited to a maximum of 60 active members? YES () NO ()			
CONTACTS:			
First Name	Middle	Last	Phone ()
Address			Fax ()
City	State	Zip	County
E-mail address:			
First Name	Middle	Last	Phone ()
Address			Fax ()
City	State	Zip	County
E-mail address:			

EXHIBIT INFORMATION

Class Number	GARDEN DESIGN DIVISION CLASSES Exhibit Title	Please ✓ Judging Period	
		1st	2nd
Example:	(List title if known.)	1st	2nd
G07 Small Platform	TBD	✓	✓

* Must be answered to qualify for certain Sweepstakes Awards.

** Metro Atlanta is comprised of Clayton, Cobb, DeKalb, Fulton and Gwinnett Counties.



2006 HORTICULTURE DIVISION ENTRY FORM

MAIL TO: DARLENE PALMER
 1534 Humphries Road
 Conyers, GA 30012

PHONE: 770-388-9020

Your early entries are greatly appreciated. Please type or print clearly in black ink.
 See General Rules 1, 2, and 3 prior to completing the form. Must be received by February 3, 2006.

- Please keep a copy of your Entry Form.
- During the second entry period, new entries will be accepted for the following Classes only: H04, H05, H07, H08, H12 and H20.

EXHIBITOR:

First Name	Middle	Last	Phone () ()
Address			Fax () ()
City		State	Zip
County			
E-mail address:		Principal residence inside Atlanta metro area? ** YES () NO ()	Plant Society:
If member of Garden Club*, (a) Full name of Garden Club _____ Garden Club of GA District			
(b) Primary County _____			
(c) Does the majority of its membership reside inside the Atlanta metro area? ** YES () NO ()			
(d) Is your garden club limited to a maximum of 60 active members? YES () NO ()			
Are you a first-time Exhibitor in the Southeastern Flower Show? YES () NO () NOVICE? YES () NO () Refer to General Rule #3c (page 7).			

EXHIBIT INFORMATION

CLASS NUMBER AND SUBCLASS (if applicable)	BOTANICAL NAME See General Rule 4, Plant Identification.	COMMON NAME	SPACE REQUIRED for each specimen in Classes 17, 18, 20; 24(to help in staging)	Please check judging period	
examples: H14.02 H05	Hedera helix TBD "to be determined"	English Ivy TBD	14" h x 12" w x 6" d N/A	1st	2nd*
				✓	✓
				✓	✓

*Applies to Classes H04, H05, H07, H08, H12 and H20 only. **Must be answered to qualify for certain Sweepstakes Awards. (OVER)



2006 PROFESSIONAL DESIGN DIVISION ENTRY FORM

Please type or print clearly in black ink.
See General Rules prior to completing the form.

BY INVITATION ONLY

MAIL TO: ELIZABETH MARTIN
108 Wakefield Drive
Atlanta, GA 30309

DEADLINE: JANUARY 19, 2006
PHONE: 404-351-8208
EMAIL: elizmartin@aol.com
FAX: 404-351-8210

EXHIBITOR:

First Name	Middle	Last	Phone ()
Address			Fax ()
City	State	Zip	County
E-mail address:			
Are you a first-time Exhibitor in the Southeastern Flower Show?			YES () NO ()

CO-EXHIBITOR (IF ANY):

First Name	Middle	Last	Phone ()
Address			Fax ()
City	State	Zip	County
E-mail address:			
Are you a first-time Exhibitor in the Southeastern Flower Show?			YES () NO ()

STATE HOW YOU WANT THE SHOWCARD TO READ: (Name, City and State)

Example: SMITHY FLORISTRY
ATLANTA, GA

Class Number	PROFESSIONAL DESIGN DIVISION Exhibit Title	Please ✓ Judging Period	
Example:	(List title if known.)	1st	2nd
PD01 Mass	TBD	✓	✓



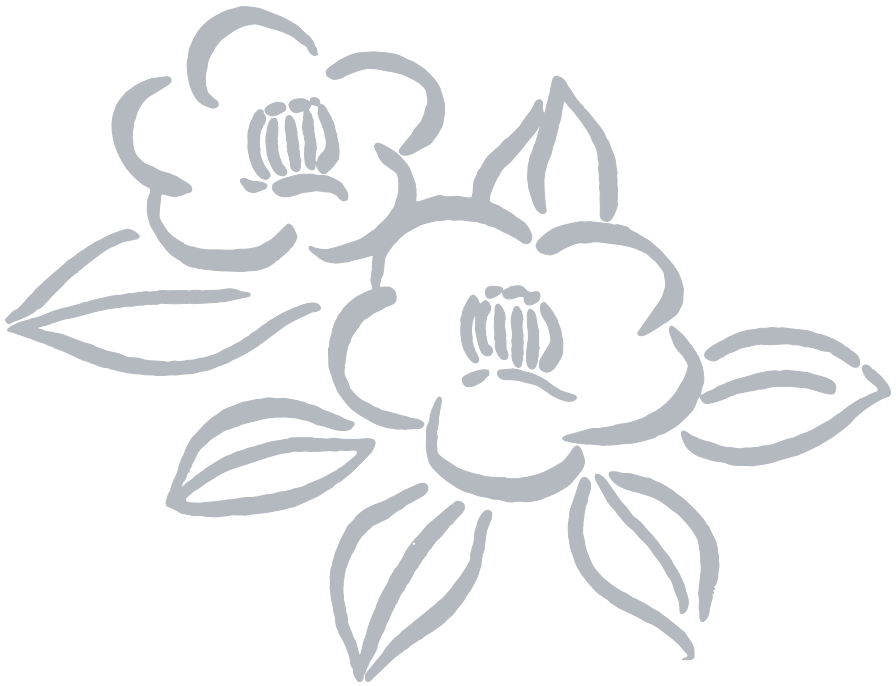

2006 SOUTHEASTERN FLOWER SHOW

Name: _____

Class: _____

Entry #: _____

Title of Exhibit: _____

PLANT LIST:

(please print clearly)

Botanical Name	Common Name
1.	
2.	
3.	
4.	
5.	
6.	
7.	
8.	
9.	
10.	
11.	
12.	
13.	
14.	

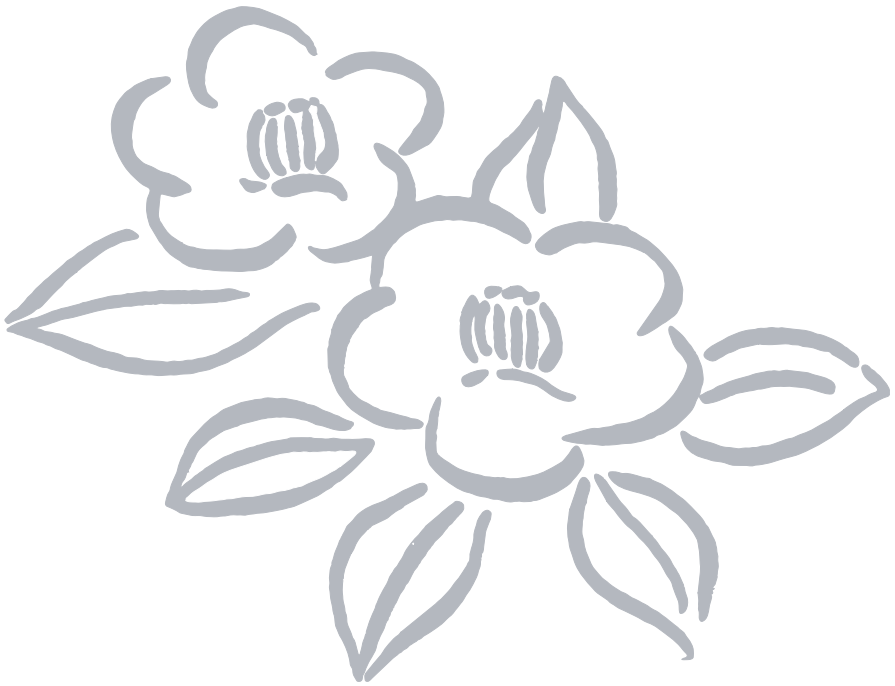

GEORGIA'S PROTECTED AND ENDANGERED PLANTS

Plants listed below specified by either federal or state statutes. Out of state exhibitors must comply with protected and endangered species lists from their states. For complete state listings check appropriate state agencies.

1. *Allium speculae* (Flatrock Onion)
2. *Amphianthus pusillus* (Pool Sprite, Snorkelwort) ¹
3. *Arabis georgiana* (Georgia Rockcress)
4. *Arnoglossum diversifolium*
(Variable-leaf Indian-plantain)
5. *Asplenium heteroresiliens* (Wagner Spleenwort)
6. *Balduina atropurpurea* (Purple Honeycomb Head)
7. *Baptisia arachnifera* (Hairy Rattleweed)
8. *Calamintha ashei* (Ochoopee Dunes Wild Basil)
9. *Carex baltzellii* (Baltzell Sedge)
10. *Carex biltmoreana* (Biltmore Sedge)
11. *Carex dasycarpa* (Velvet Sedge)
12. *Carex manhartii* (Manhart Sedge)
13. *Carex misera* (Wretched Sedge)
14. *Carex purpurifera* (Purple Sedge)
15. *Ceratiola ericoides* (Rosemary)
16. *Chamaecyparis thyooides* (Atlantic White Cedar)
17. *Clematis socialis* (Alabama leather-flower)
18. *Croomia pauciflora* (Croomia)
19. *Cuscuta harperi* (Harper Dodder)
20. *Cymophyllus fraseri* (Fraser Sedge)
21. *Cyripedium acaule* (Pink Ladyslipper)
22. *Cyripedium calceolus* (Yellow Ladyslipper)
23. *Draba aprica* (Granite Whitlow-wort)
24. *Echinacea laevigata* (Smooth Purple Coneflower) ⁶
25. *Elliottia racemosa* (Georgia Plume)
26. *Epidendrum conopseum* (Greenfly Orchid)
27. *Evolvulus sericeus* (Creeping Morning-glory)
28. *Fimbristylis perpusilla* (Harper Fimbry)
29. *Fothergilla gardenii* (Dwarf Witch-alder)
30. *Gentianopsis crinita* (Fringed Gentian)
31. *Gymnoderma lineare* (Rock Gnome Lichen)
32. *Hartwrightia floridana* (Hartwrightia)
33. *Helonias bullata* (Swamp Pink)
34. *Hexastylis shuttleworthii* v. *harperi*
(Harper Wild Ginger)
35. *Hydrastis canadensis* (Goldenseal)
36. *Hymenocallis coronaria* (Shoals Spiderlily)
37. *Illicium floridanum* (Florida Anise-tree)
38. *Isoetes melanospora* (Black-spored Quillwort)
39. *Isoetes tegetiformans* (Mat-forming Quillwort)
40. *Isotria medeoloides* (Small Whorled Pogonia) ^{6,7}
41. *Jeffersonia diphylla* (Twinleaf)
42. *Leavenworthia exigua* v. *exigua* (Glade-cress)
43. *Lindera melissifolia* (Pondberry) ^{2,5}
44. *Lindernia saxicola* (Rock False Pimpernel)
45. *Litsea aestivalis* (Pondspice)
46. *Lysimachia fraseri* (Fraser Loosestrife)
47. *Lythrum curtissii* (Curtiss Loosestrife)
48. *Marshallia mohrii* (Coosa Barbara Buttons) ¹
49. *Marshallia ramosa* (Pineland Barbara Buttons)
50. *Matelea alabamensis* (Alabama Milkvine)
51. *Matelea pubiflora* (Trailing Milkvine)
52. *Myriophyllum laxum* (Lax Water-milfoil)
53. *Nestronia umbellula* (Indian Olive)
54. *Neviusia alabamensis* (Alabama Snow-wreath)
55. *Oxypolis canbyi* (Canby Dropwort) ⁶
56. *Panicum hirstii* (Hirst Panic Grass)
57. *Penstemon dissectus* (Cutleaf Beardtongue)
58. *Physostegia leptophylla* (Narrowleaf Obedient Plant)
59. *Pinguicula primuliflora* (Clearwater Butterwort)
60. *Pityopsis pinifolia* (Sandhill Golden-aster)
61. *Platanthera integrilabia* (Monkeyface Orchid)
62. *Ptilimnium nodosum* (Mock Bishop-weed) ^{1,6}
63. *Quercus oglethorpensis* (Oglethorpe Oak)
64. *Rhododendron prunifolium* (Plumleaf Azalea)
65. *Rhus michauxii* (Dwarf Sumac) ^{3,6,7}
66. *Sabatia capitata* (Cumberland Rose Gentian)
67. *Sageretia minutiflora* (Tiny-leaf Buckthorn)
68. *Sagittaria secundifolia* (Little River Water-plantain) ¹
69. *Salix floridana* (Florida Willow)
70. *Sanquisorba canadensis* (Canada Burnet)
71. *Sarracenia flava* (Yellow Flytrap)
72. *Sarracenia leucophylla* (Whitetop Pitcherplant)
73. *Sarracenia minor* (Hooded Pitcherplant)
74. *Sarracenia oreophila* (Green Pitcherplant) ^{1,6}
75. *Sarracenia psittacina* (Parrot Pitcherplant)
76. *Sarracenia purpurea* (Purple Pitcherplant)
77. *Sarracenia rubra* (Sweet Pitcherplant) ^{1,6}
78. *Schisandra glabra* (Bay Star-vine)
79. *Schwalbea americana* (Chaffseed) ^{3,5,6}
80. *Scutellaria montana* (Large-flower Skullcap)
81. *Scutellaria ocmulgee* (Ocmulgee Skullcap)
82. *Sedum nevii* (Nevius Stonecrop)
83. *Sedum pusillum* (Dwarf Granite Stonecrop)
84. *Senecio millefolium* (Blue Ridge Golden Ragwort)
85. *Shortia galacifolia* (Oconee Bells)
86. *Sibbaldiopsis tridentata* (Three-tooth Cinquefoil)
87. *Sideroxylon thornei* (Swamp Buckthorn)
88. *Silene polypetala* (Fringed Campion) ³
89. *Silene regia* (Royal Catchfly)
90. *Spiraea virginiana* (Virginia Spirea) ^{4,6,8}
91. *Spiranthes magnicamporum*
(Great Plains Ladies-tresses)
92. *Stewartia malacodendron* (Silky Camellia)
93. *Stylisma pickeringii* var. *pickeringii*
(Pickering Morning-glory)
94. *Thalictrum cooleyi* (Cooley Meadowrue) ⁶
95. *Thalictrum debile* (Trailing Meadowrue)
96. *Tillandsia recurvata* (Ball-moss)
97. *Torreya taxifolia* (Florida Torreya) ³
98. *Trientalis borealis* (Northern Starflower)
99. *Trillium persistens* (Persistent Trillium)
100. *Trillium reliquum* (Relict Trillium) ¹
101. *Veratrum woodii* (Ozark Bunchflower)
102. *Viburnum bracteatum* (Limerock Arrow-wood)
103. *Waldsteinia lobata* (Piedmont Barren Strawberry)
104. *Xerophyllum asphodeloides* (Eastern Turkeybeard)
105. *Xyris tennesseensis* (Tennessee Yellow-eyed Grass) ^{1,8}

Also threatened or endangered in: ¹ = AL; ² = AR; ³ = FL; ⁴ = KY; ⁵ = MS; ⁶ = NC; ⁷ = SC; ⁸ = TN.

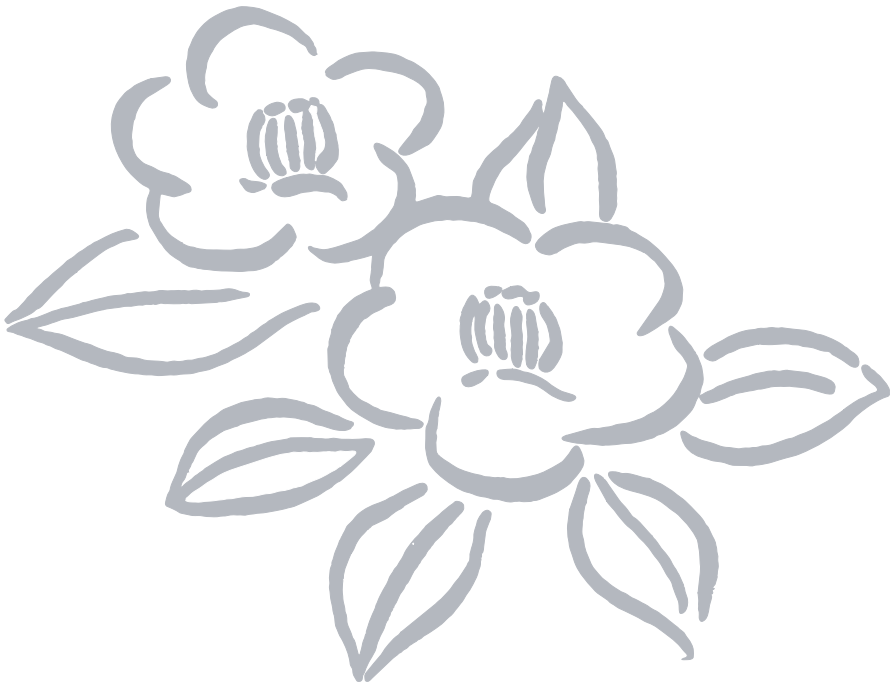

MAP

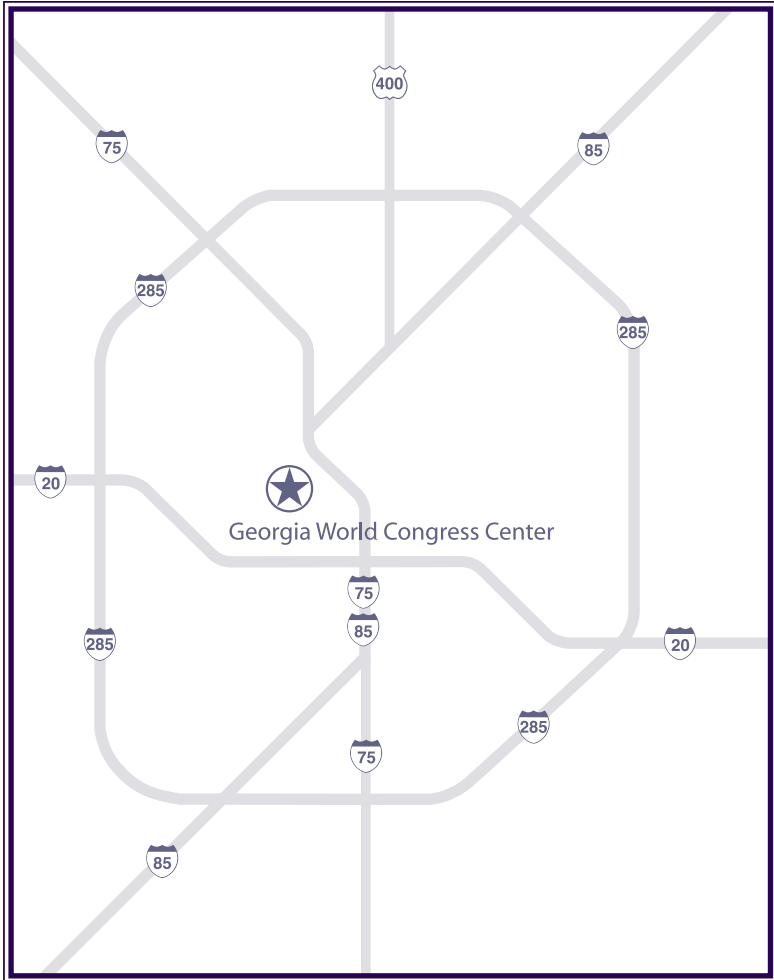

Southeastern
FLOWER SHOW

DIRECTIONS

DIRECTIONS FOR DROP OFF, PARKING AND DRIVING: GWCC - HALL C

DROP OFF:

PASSENGERS AND EXHIBITS IN THE HORTICULTURE DIVISION may be dropped off* at the entrance to Hall C on Northside Drive (Marked with a large, blue "C" and marked "Buses Only.") This entrance is on the same level as the Show Exhibit Hall.

Instructions for dropping off ALL OTHER EXHIBITS (including Garden Design and Artistic Floral Design) will be given to Exhibitors with Acknowledgement of their Entry. (Call your Class Advisor for additional information.)

PASSENGERS may also be dropped off at the West Plaza Entrance located across the plaza from Gold Deck Parking. (Directions to Gold Deck below). NOTE: Passengers dropped off here must take the escalator down to the Exhibit Hall.

PARKING:

Underground parking is available in the Gold Deck. The Entrance to the Gold Deck is on Northside Drive between the Georgia Dome and Building C. It is marked with a large, blue "C" and "Entrance to Gold Deck." (This entrance is just south of the drop off entrance, also marked with a large blue "C" and marked "Buses Only.")

Surface parking is available in the Blue Lot, directly across Northside Drive from Hall C, and in the Yellow Lot, just north of Hall C, at the corner of Northside Drive and Simpson Street, across Simpson Street from Hall C. (After dropping off a passenger at the "Buses only" drop off area, traffic flow continues directly toward the Yellow Lot, for easy driving access to the Yellow Lot, across Simpson Street.)

DRIVING DIRECTIONS:

FROM THE NORTH: Take I-75 south to Northside Drive (exit 252). Turn right on Northside Drive. Stay on Northside Drive for about 3 miles, staying right as the road splits, and veering right as it goes through Marietta Street intersection and the North Avenue intersection. GWCC Building C is on the left, immediately after Simpson Street (Yellow Lot parking, left on Simpson), and immediately before the Georgia Dome.

Or

Take I-85/I-75 south to North Avenue (Exit 249D). Turn right on North Avenue and go about .08 mile through the Georgia Tech campus. Turn left on Northside Drive. GWCC Building C is on the left, immediately after Simpson Street (Yellow Lot parking, left on Simpson), and immediately before the Georgia Dome.

FROM THE SOUTH: Take I-75/I-85 north to the Central Avenue (Downtown) Exit (Exit 246). Go left from the exit ramp, over the highway and continue (a total of about a mile from the Exit) on Central Avenue. Turn left on Martin Luther King, Jr. Drive.

Continue about .08 mile and turn right onto Northside Drive. GWCC Building C is located on your right immediately following the Georgia Dome.

FROM THE EAST: Take I-20 west to the Windsor St./Spring St. Exit (Exit 56B.) (Stay to the left of the I-75/I-85 North and South exit lanes.) At the end of the ramp, turn right onto Windsor St., which becomes Spring Street. Follow Spring Street and turn left onto Martin Luther King, Jr. Drive. Turn right onto Northside Drive. GWCC Building C is located on your right immediately following the Georgia Dome.

FROM THE WEST: Take I-20 east to the Windsor St./Spring St./Turner Field Exit (Exit 56B). Turn left onto Windsor St., which becomes Spring St. Follow Spring St. and turn left onto Martin Luther King, Jr. Drive. Turn right onto Northside Drive. GWCC Building C is located on your right immediately following the Georgia Dome.

* After parking, please return to the Exhibit Hall area for registration and installation of exhibits as described on page 17.

Southeastern FLOWER SHOW

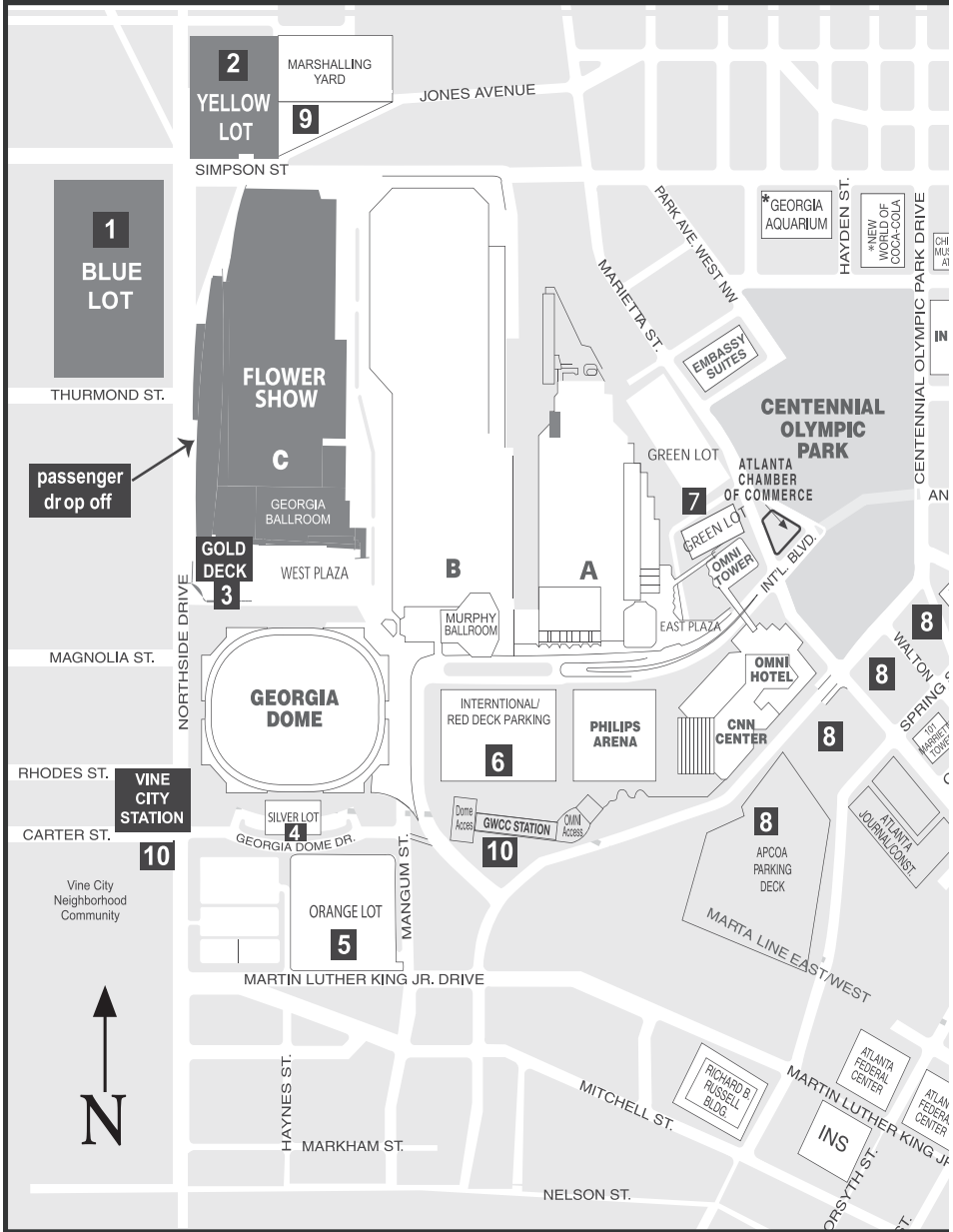

GEORGIA WORLD CONGRESS CENTER • February 8-12, 2006

Key

Flower Show

- C** Georgia World Congress Center Exhibit Halls C1-2

General Parking

- 1** Blue Lot (\$8) Recommended Lot
- 2** Yellow Lot (\$8) Recommended Lot
- 3** Gold Deck (\$10) Recommended Lot
- 4** Silver Lot (\$10)
- 5** Orange Lot (\$10)
- 6** International/Red Deck (\$10)
- 7** Green Lot (\$8)
- 8** Off campus Parking (various prices)

Marshalling Yard

- 9** Jones St. Marshalling Yard

Other Transport

- 10** MARTA Stations-
Vine City Station-Recommended
GWCC Station

Hotels

- Omni Hotel
- Embassy Suites
- Holiday Inn
- Wyndham Hotel

